



Transformer Oil Cooling Solutions

Series
NTG/ TGCL
NTF/ TFBR/ VTTF



INNOVATION AND EXPERIENCE
AT YOUR SERVICE

MANUFACTURING IN PORTUGAL SINCE **1946**

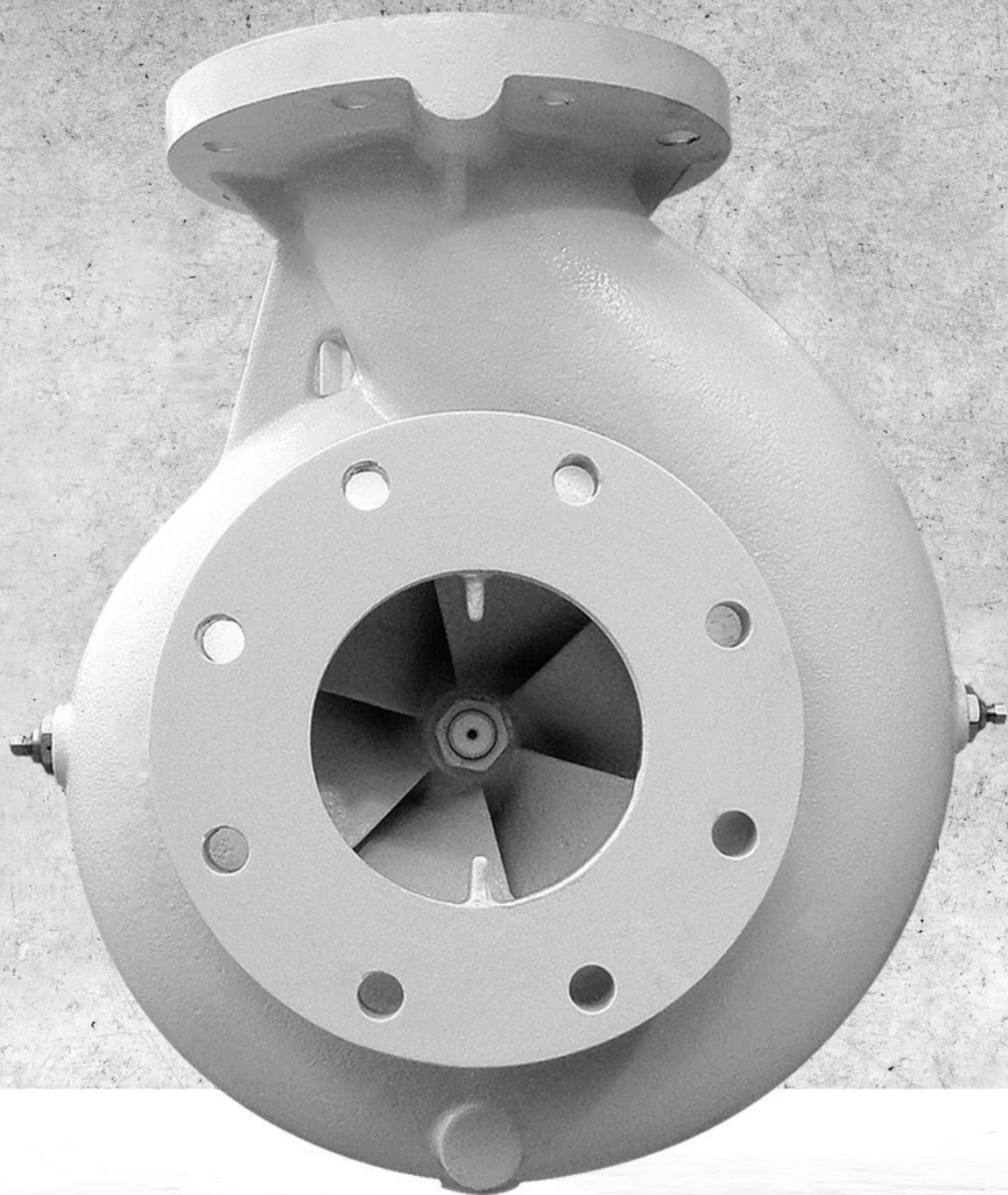



INDEX

- 3 The Company
- 4 Portfolio
- 5 Development

- 8 Pumps
- 9 Range chart 50 Hz
- 10 Low temperature versions (LT)
- 11 Nomenclature
- 12 Applications
- 13 NTG - Inline Axial Pumps
- 18 TGCL - End Suction Radial Pumps

- 24 Fans
- 25 Fans range
- 26 Applications
- 27 NTF - Short Casing Fan
- 30 TFBR - Short Casing Fan
- 32 VTTF - Long Casing Fan

- 34 PSO - Product Selector Online

All informations and specifications in this catalogue may be changed by EFAFLU without prior notice. Product images are for illustrative purposes only and may differ from the actual product.

For other products please contact our sales and technical departments:
export@efafllu.pt (export markets).

Assembly line



Water test lab

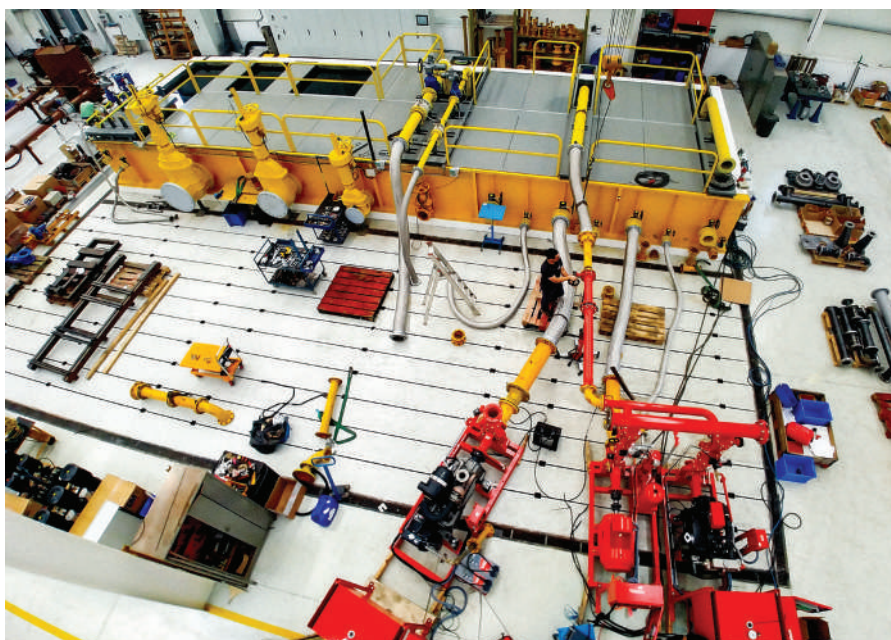

Oil test lab





EFAFLU's facilities

EFAFLU, based in Portugal, has been a leading manufacturer of pumps and fans since 1946.

Since our foundation, we have focused on designing, developing, manufacturing, and servicing pumps and fans. Our products and equipment are found on all continents, operating in the most demanding and challenging conditions and environments.

EFAFLU is part of a private group of companies in Portugal, the United Kingdom, and Spain, with more than 100 employees. Our R&D department, manufacturing and testing facilities, and dedicated laboratories are all located in Portugal.

We guarantee the availability of spare parts for up to 20 years.

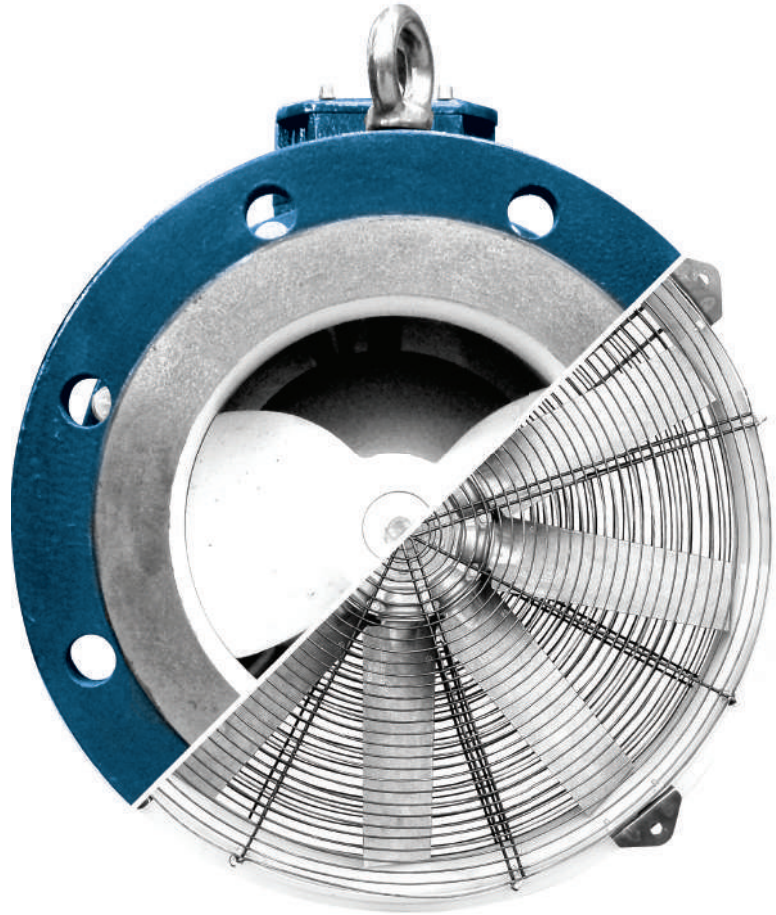

EFAFLU is able to develop tailor-made solutions or adapt existing products to meet their customers' specific requirements, ensuring optimal performance and quality for their transformers.

For our pump range, we offer inline and elbow solutions from DN65 up to DN250, with various construction materials and options, all according to EN IEC 60076-22-5. For our fan range, we provide short and long casing solutions from 450 up to 1000 mm, with several corrosion protection levels and options, all according to EN IEC 60076-22-6. We have dedicated laboratories capable of performing Routine and Type Tests according to EN IEC 60076-22-5 and EN IEC 60076-22-6.

We use the most efficient motors in compliance with European regulations to ensure optimal performance and low energy consumption of our products. To maintain the quality of our products, we offer high-quality castings and a high degree of corrosion protection. As standard, we provide C5 corrosion protection with the option for customers to choose any RAL colour free of charge.

Our R&D team continuously designs and develops state-of-the-art solutions using advanced software and laboratory technologies, such as thermal and mechanical software analysis, computational fluid dynamics, and 3D printing solutions. For offshore applications, we offer CX corrosion protection according to ISO 12944

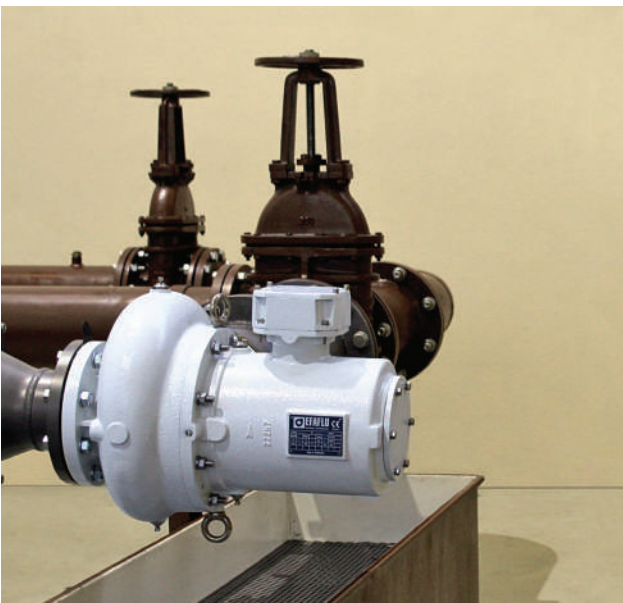
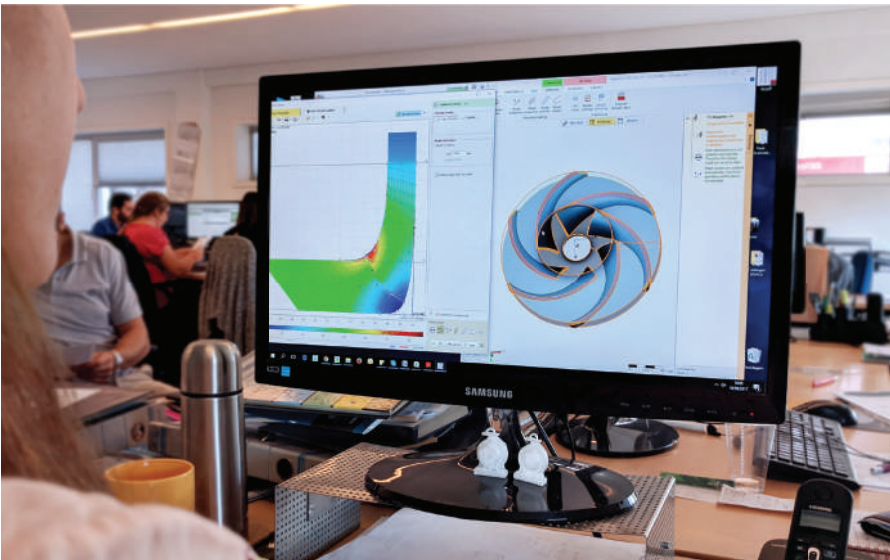
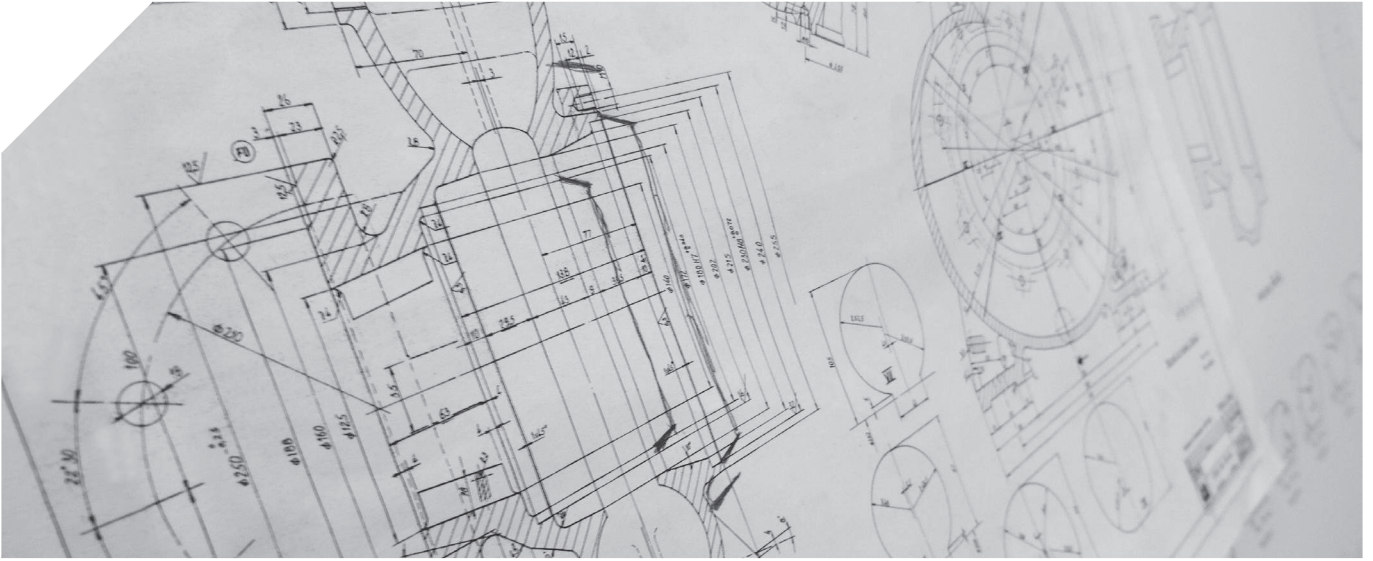

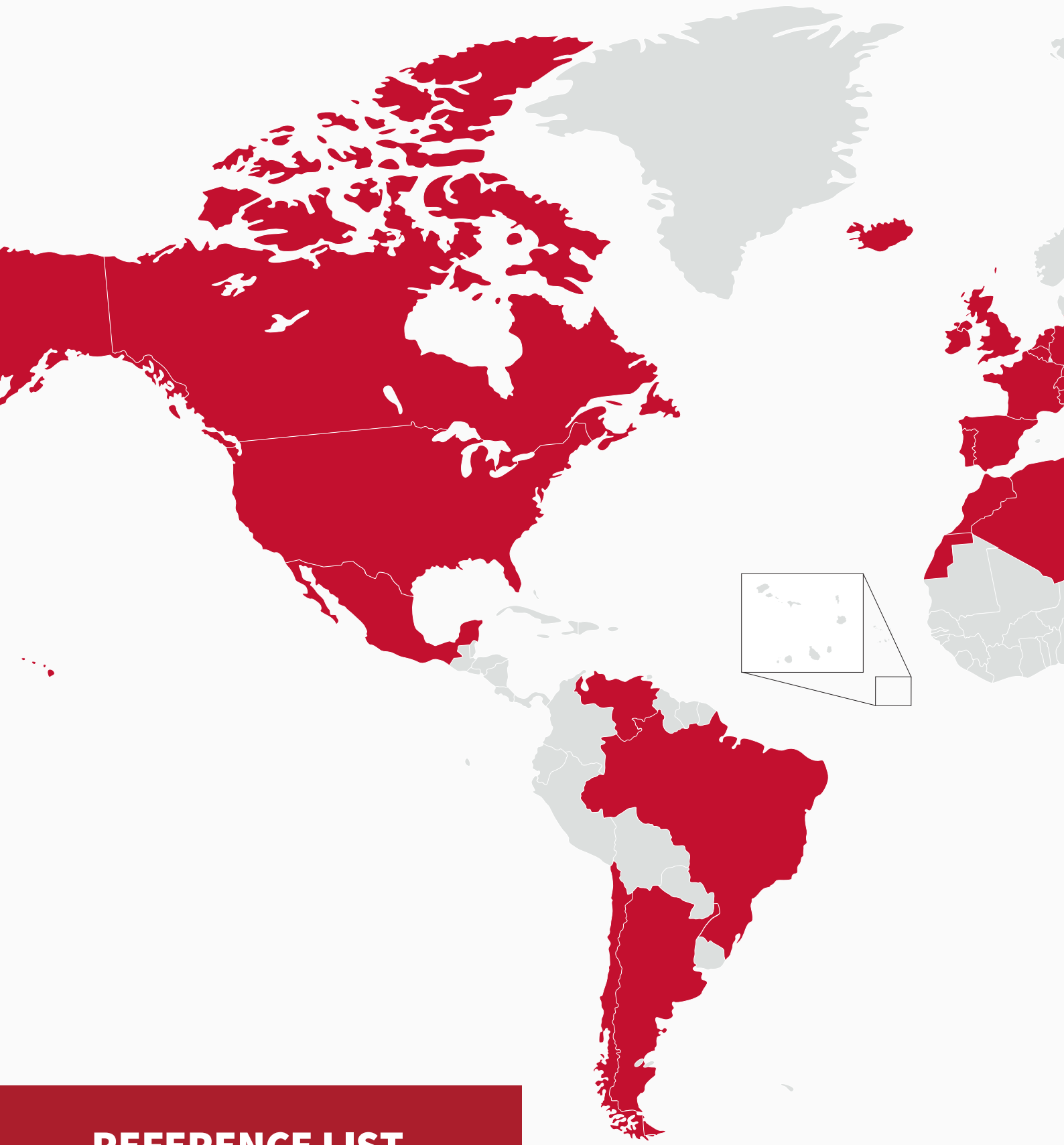

REFERENCE LIST

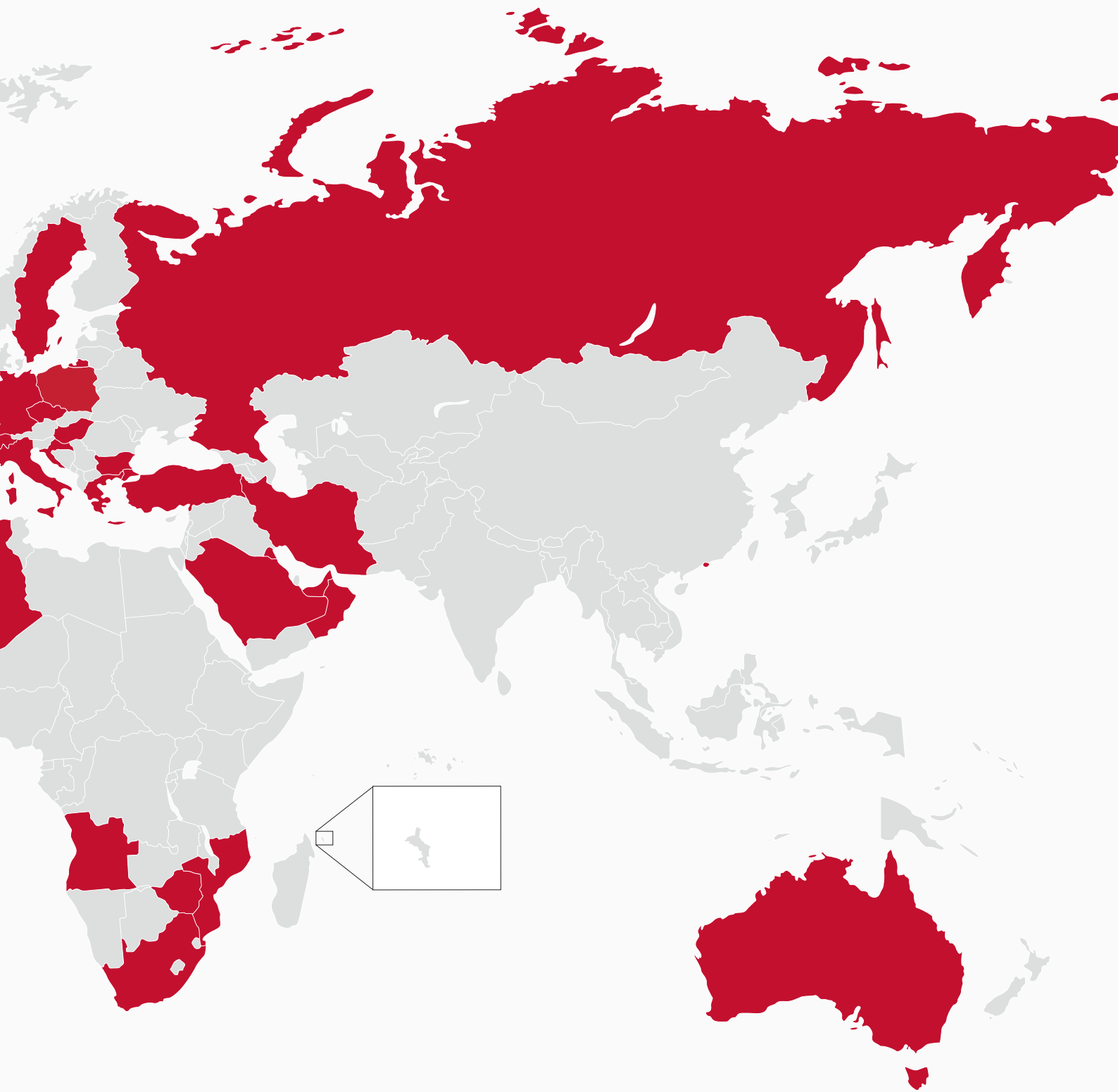

Pumps

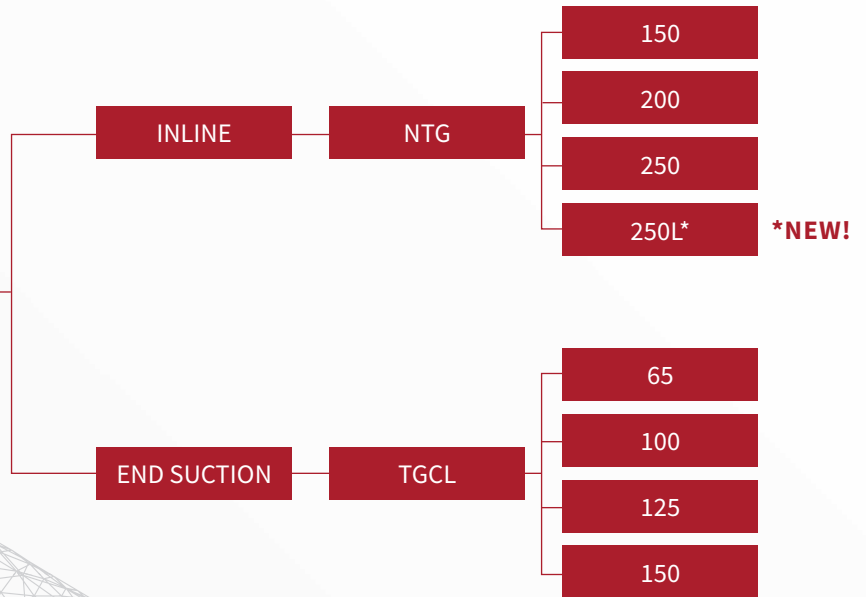

In our range, we offer inline and elbow solutions, NTG and TGCL respectively, from DN65 up to DN250, in different construction materials with a wide range of options.

Our pumps are designed and approved according to EN IEC 60076-22-5, delivered together with the certificate and test report.

They are designed to work with mineral oil, synthetic or natural ester at temperatures from -45°C to +115°C, manufactured from EN-GJL-250 or EN-GJS-400 cast iron, and equipped with viton, silicone or fluorosilicone gaskets to guarantee reliability even in the most extreme working conditions.

To ensure vibration-free performance and extend bearing life, we perform dynamic balancing of the rotor according to ISO 21940-11.

Range chart 50 Hz

All the curves shown in this catalog were obtained with mineral transformer oil. The correspondent density and kinematic viscosity at 60 °C are 847 kg/m³ and 5,8 mm²/s respectively.

The curves and motor running / trip data are valid for transformer oils with a density equal or lower than 890 kg/m³, and a kinematic viscosity equal or lower than 16 mm²/s at the desired working temperature. For transformer oils with a density and/or kinematic viscosity that fall outside the stipulated interval above please contact EFAFLU Sales Team for customized selection.

The hydraulic curves are shown as Head (m) in y axis versus Flow (m³/h) in x axis. Showing Head (m) instead of Pressure (kPa) eliminates the effect of density used to obtain the curves from the selection and, thus, avoid possible errors.

If your input for selection is Pressure (kPa) instead of Head (m), please use the equation below.

$$H (m) = \frac{P (kPa) \times 1000}{\rho \left(\frac{kg}{m^3}\right) \times g \left(\frac{m}{s^2}\right)}$$

Where:

ρ = density of the working fluid at the desired working temperature

$g = 9,81$

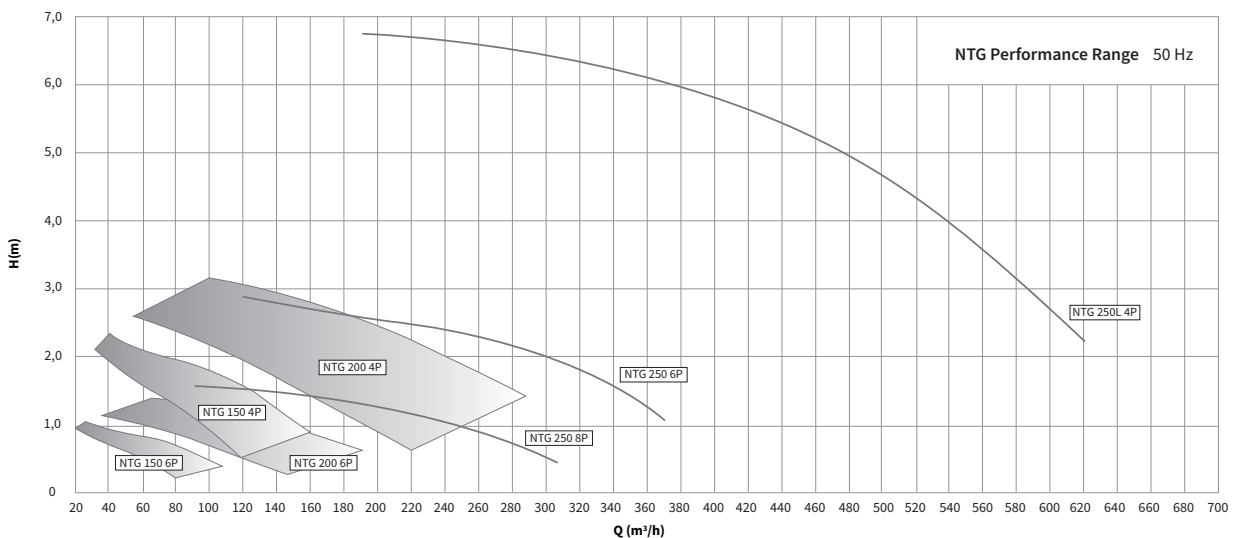
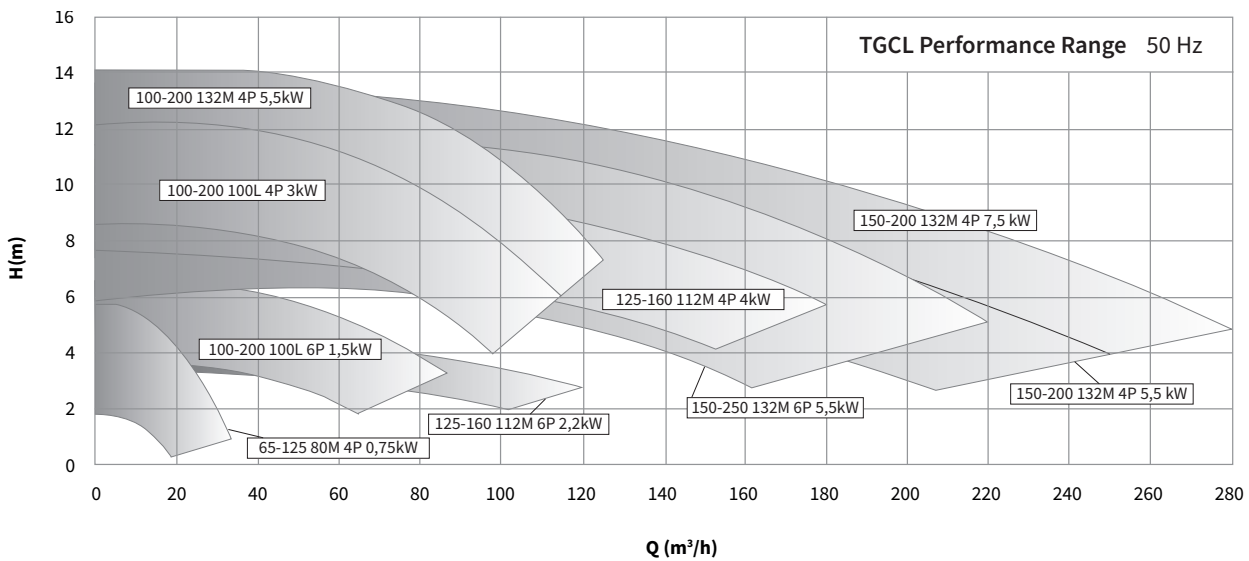

Pumps range approved for -45°C cold start test

Extreme conditions, for instance cold environments, present potential risks for pumps, such as high oil viscosity, motor overheating, and changes in material behavior that can lead to failures during startup.

TGCL and NTG pumps have successfully undergone cold start testing at -45°C in an independent laboratory. The tests included rotation speed, temperature monitoring, and electrical data analysis. While EN IEC 60076-22-5 only requires testing down to -25°C, EFAFLU has chosen to test down to -45°C, demonstrating our pumps' capability to operate in the most challenging conditions.



Low temperature versions (LT)

TGCL LT and NTG LT are transformer oil pumps for temperatures as low as to -60°C (ambient temperature)* enabling our pumps to be fitted in the most extreme conditions.

* Starting temperature of the oil must be -45°C or higher and kinematic viscosity lower than 7200 mm²/s.

TECHNICAL SPECIFICATIONS	PUMPS			
	NTG GA LT	NTG SA LT	TGCL GG LT	TGCL SS LT
Impeller	Axial	Axial	Radial	Radial
Impeller material	Aluminium	Aluminium	EN-GJL-250	EN-GJS-400
Casing material	EN-GJL-250	EN-GJS-400	EN-GJL-250	EN-GJS-400
Shaft	AISI 420	AISI 420	AISI 420	AISI 420
Gaskets	Silicone	Silicone	Silicone	Silicone
Bearings	Ball bearings	Ball bearings	Ball bearings	Ball bearings
Lubrication	Dielectric oil	Dielectric oil	Dielectric oil	Dielectric oil
OPERATING CONDITIONS				
Ambient Temperature	-50°C to 40°C	-60°C to 40°C	-50°C to 40°C	-60°C to 40°C

Pump model nomenclature **NTG**

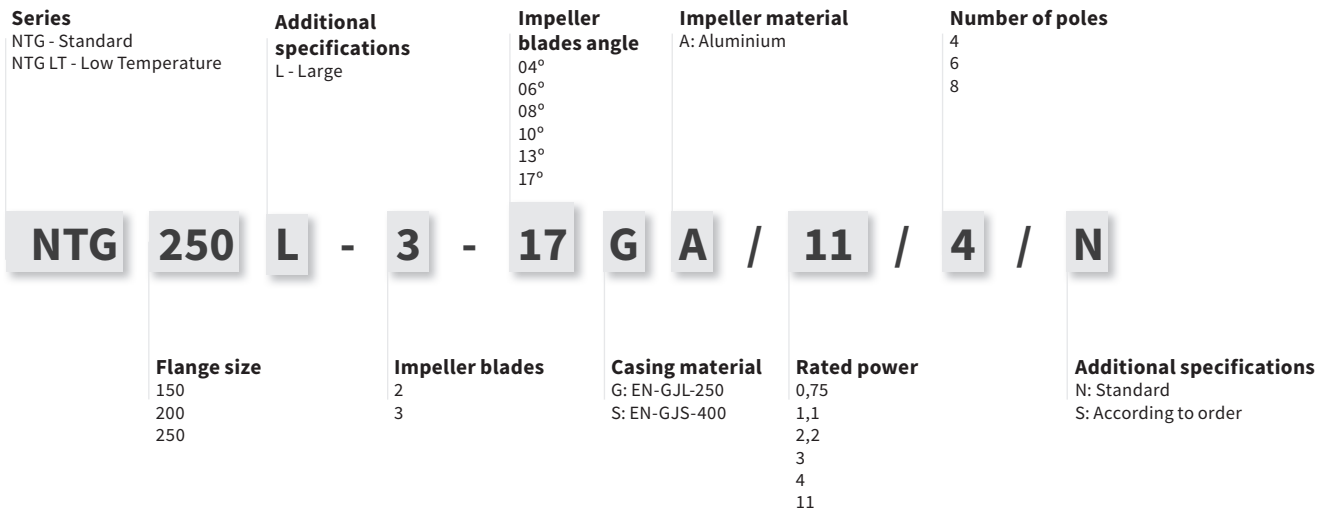

Pump model nomenclature **TGCL**

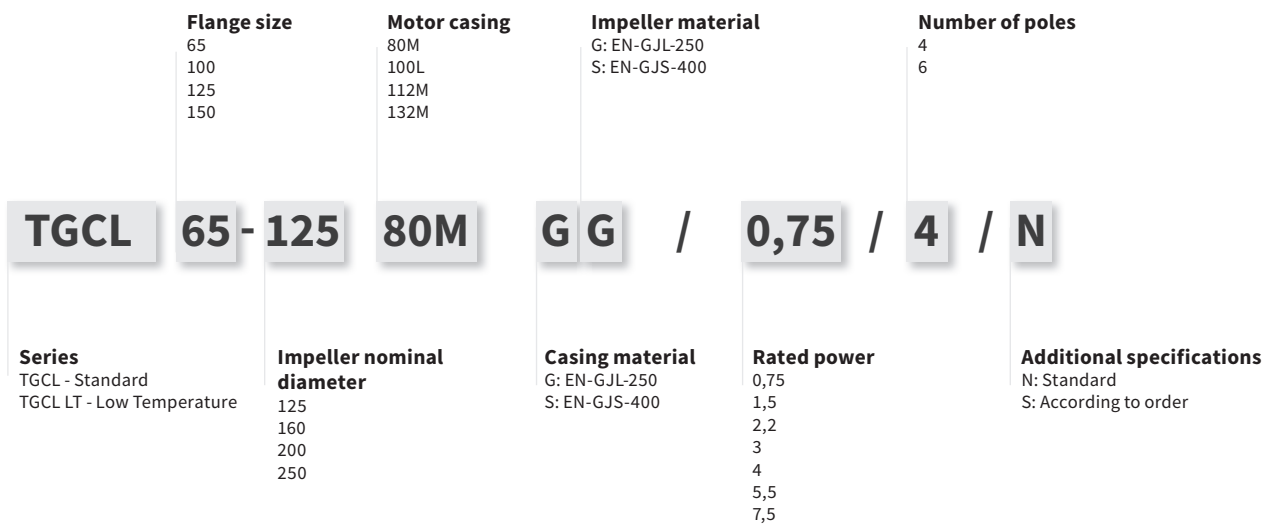

Applications

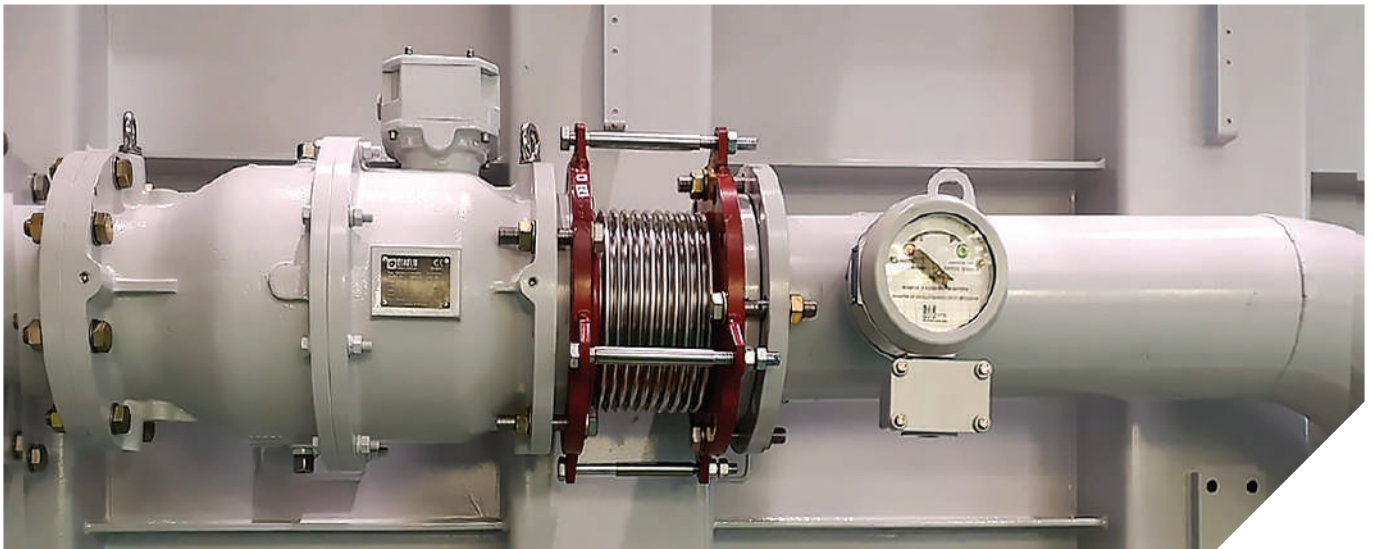
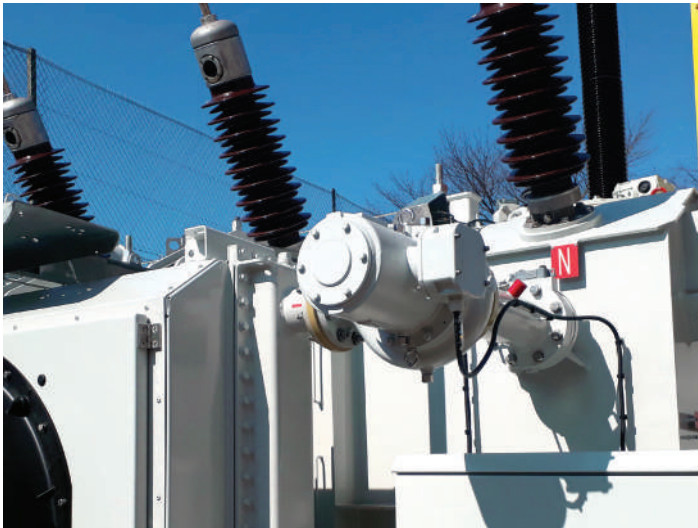



Characteristics

NTG is an inline axial type pump, from DN150 up to DN250, manufactured in EN-GJL-250 or EN-GJS-400 cast iron with IP67 protection.

Maintenance free SKF bearings.

NTG pumps operate with low noise levels, validated at our laboratory. The pumps are supplied as standard with C5H corrosion protection (according to ISO 12944). However, C5VH and CX are also available.

They can be installed horizontally or vertically, with the terminal box and drain/vent plugs positioned according to order. The flanges can be DIN or ISO PN10, raised or flat-faced. Due to a wide variety of motors (4P, 6P, or 8P), they can meet the requirements of any project.

Specifications

Casing	EN-GJL-250 or EN-GJS-400
Impeller	Aluminium Al Si10 Mg
Shaft	AISI420
Terminal Box	Aluminium Al Si10 Mg
Fasteners	A4 – AISI316
IP	IP67
Optionals	ATEX (NTG 150) RAL / Munsell / British Standard C5VH / CX Raised face; Groove

Electrical data

Rated power	0,75 up to 11 kW
Poles	4/ 6/ 8
Voltages	3x400 VAC @ 50 Hz or 3x460 VAC @ 60 Hz

* Other voltages under request.

Part list

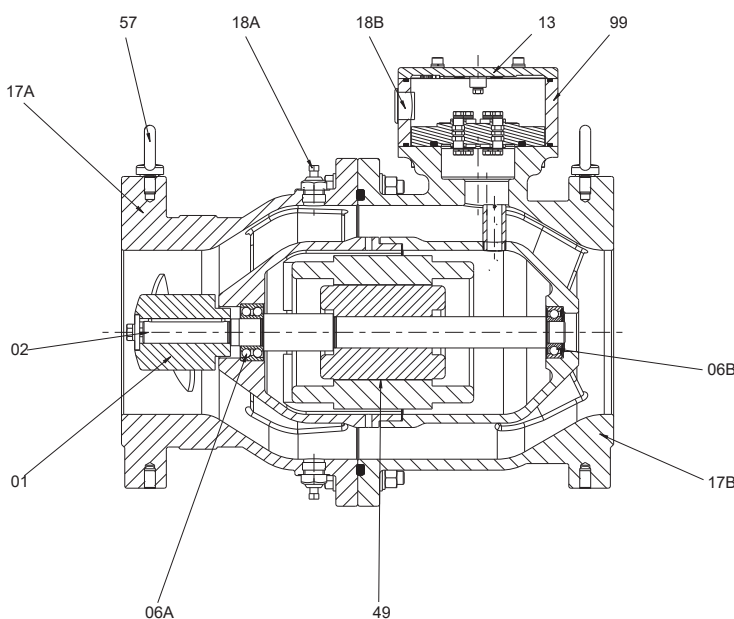

Part	Designation
01	Impeller
02	Shaft
06A	Bearing
06B	Bearing
13	Terminal box cover
17A	Suction casing
17B	Discharge casing
18A	Drain/ vent
18B	Cable gland
49	Motor
57	Eye bolt
99	Terminal box

Mounting positions - horizontal and vertical

NTG pumps can be mounted in different positions. The various mounting positions available can be simulated in PSO software. Some examples below (other positions available).

A1



B2



C3



D4



Curves According to ISO 9906 Grade 2B/ EN IEC 60076-22-5

50 Hz 400v

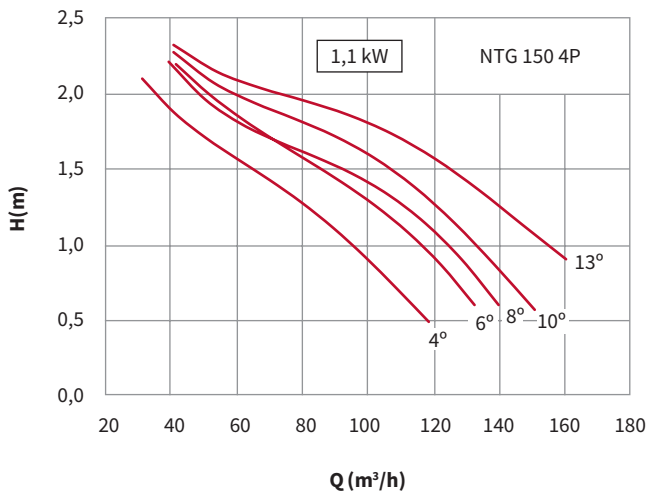

60 Hz 460v

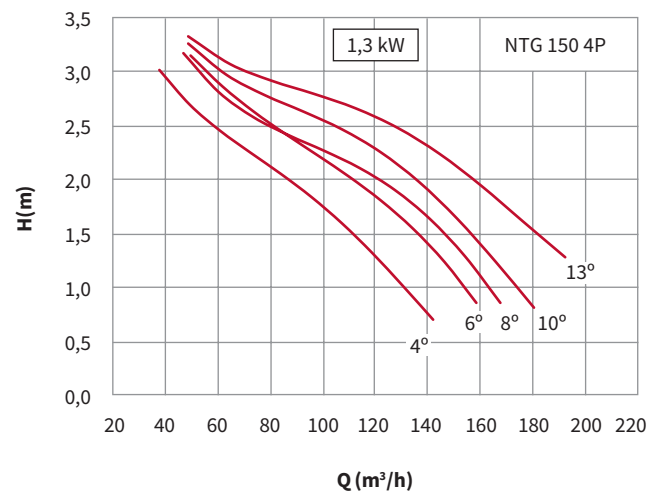

Curves According to ISO 9906 Grade 2B/ EN IEC 60076-22-5

50 Hz 400v

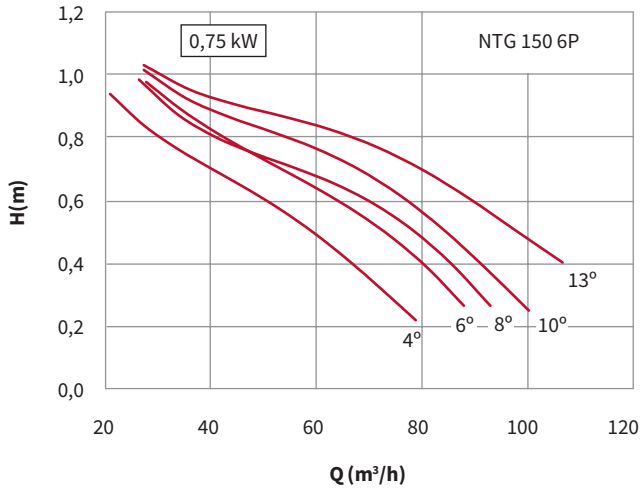

60 Hz 460v

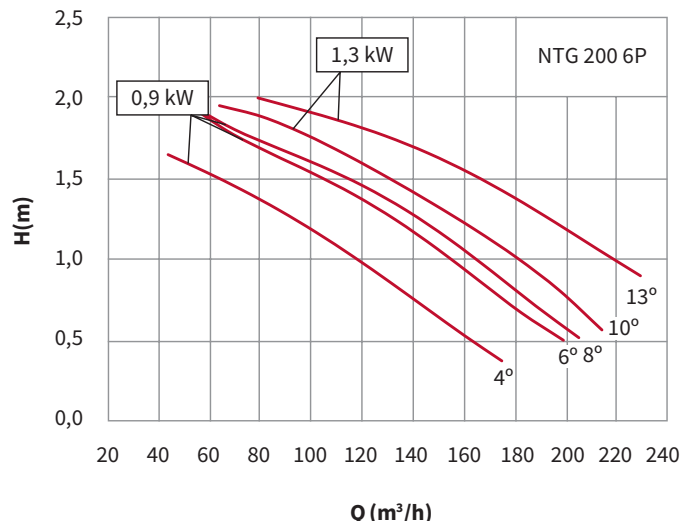
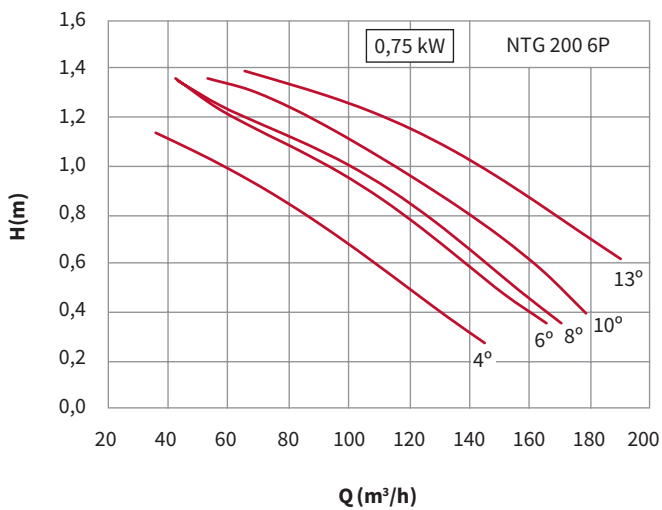
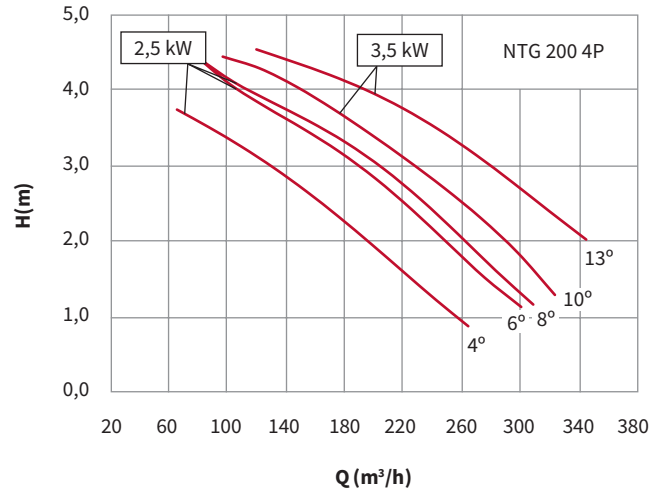
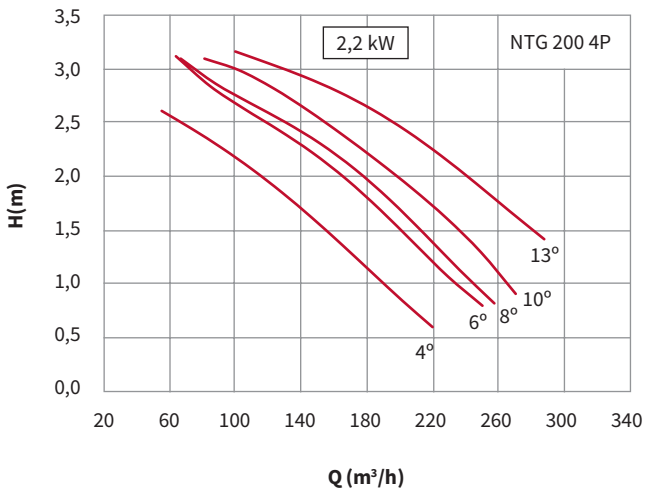
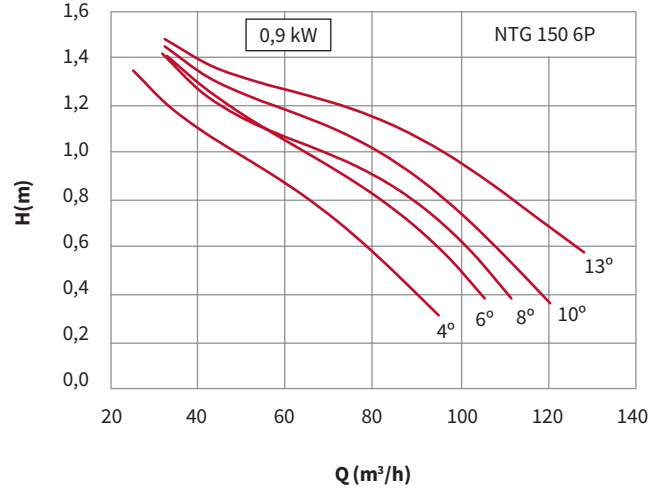

Curves According to ISO 9906 Grade 2B/ EN IEC 60076-22-5

50 Hz 400v

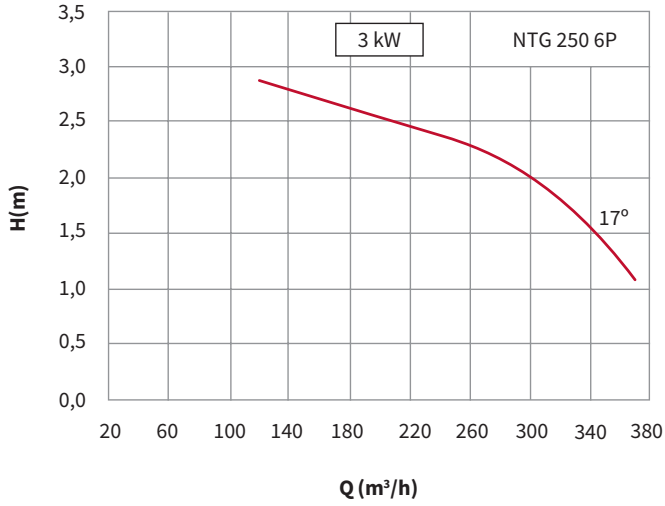

60 Hz 460v

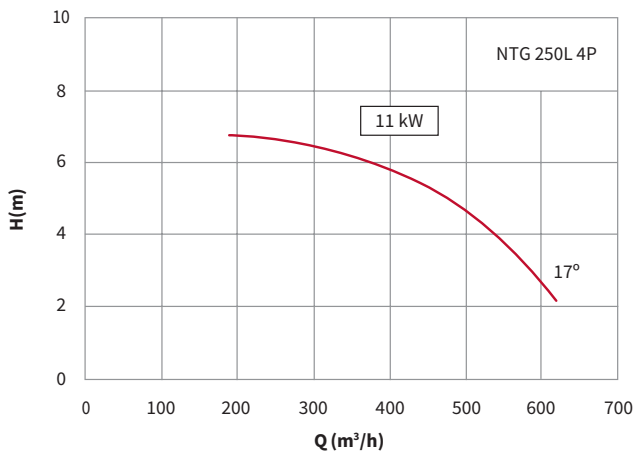
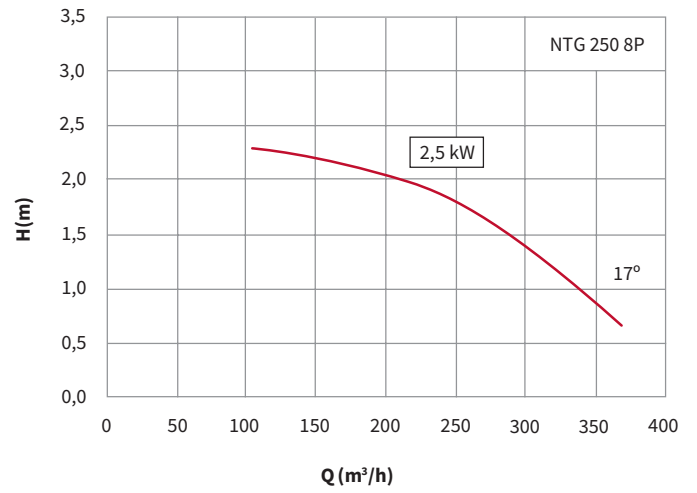
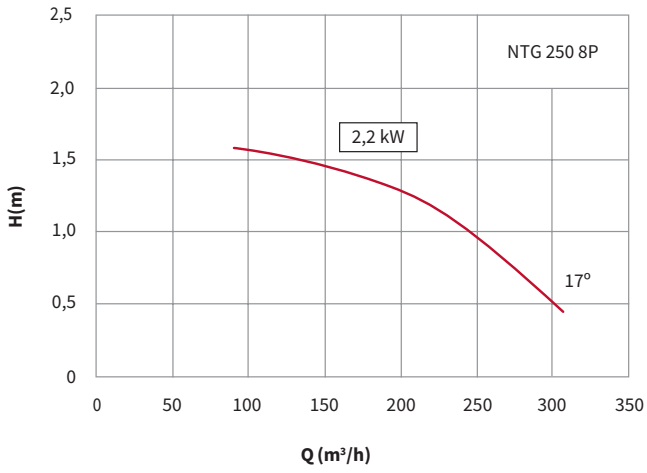
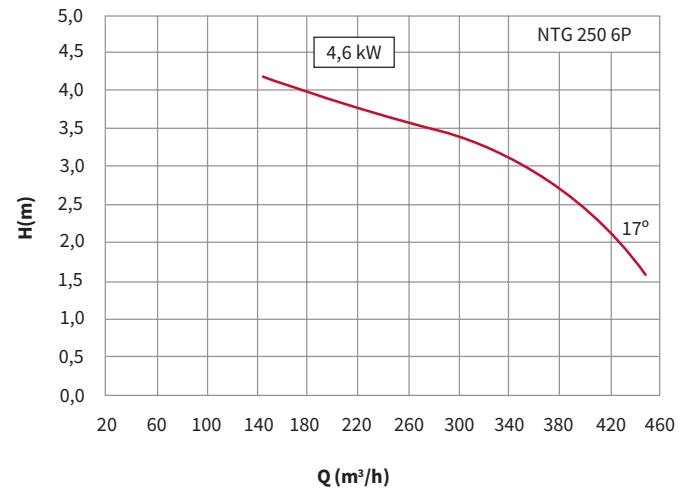

Dimensions (mm)

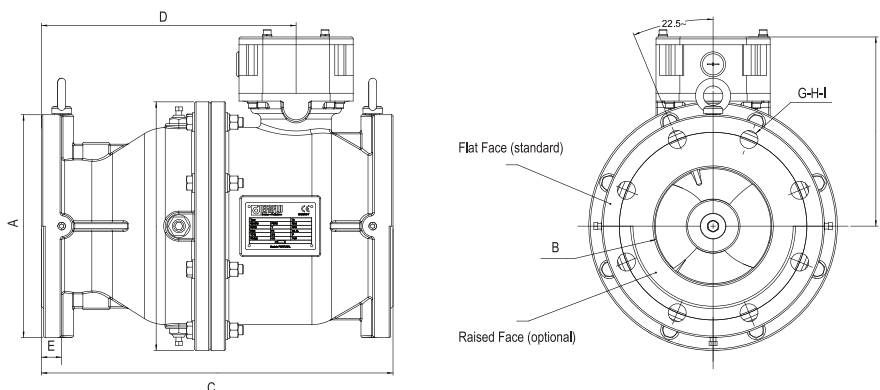

Pump	A	B	C	D	E	F	G	H	I	Weight (Kg)
NTG 150*	285	150	450	326	26	240	8	23	240	80
NTG 200	340	200	548	408	26	272	8	23	295	115
NTG 250	395	250	550	410	28	315	12	23	350	162
NTG 250L	395	250	648	508	28	315	12	23	350	209

* ATEX version available

Technical data

Model	Motor* (kW)	Poles	Frequency (Hz)	Rated Power (kW)	Voltage (V)	Connection	Rated Speed (rpm)	Power Factor	Rated Current (A)	Starting Current (A)	Trip Current (A)	Trip Current @ -10°C (A)	Trip Current @ -40°C (A)	SPL @ 1m (dBA)	SWL (dBA)
150	0,75	6	50	0,75	230/400	D / Y	950	0,67	3,7/2,1	17,2/9,9	4,0/2,3	4,6/2,6	5,1/2,9	On request	On request
		6	60	0,9	265/460	D / Y	1140	0,67	3,7/2,1	16,5/9,5	4,0/2,3	4,6/2,6	5,1/2,9	On request	On request
	1,1	4	50	1,1	230/400	D / Y	1440	0,72	4,5/2,6	34,8/20,0	5,0/2,9	5,5/3,2	7,1/4,1	44	52
		4	60	1,3	265/460	D / Y	1728	0,72	4,5/2,6	33,4/19,2	5,0/2,9	5,5/3,2	7,1/4,1	On request	On request
200	0,75	6	50	0,75	230/400	D / Y	950	0,67	3,7/2,1	17,2/9,9	4,0/2,3	4,6/2,6	5,1/2,9	42	50
		6	60	0,9	265/460	D / Y	1140	0,67	3,7/2,1	16,5/9,5	4,0/2,3	4,6/2,6	5,1/2,9	On request	On request
	1,1	6	60	1,3	265/460	D / Y	1140	0,67	5,0/2,9	25,2/14,5	5,0/3,2	6,4/3,7	7,1/4,1	On request	On request
		4	50	2,2	230/400	D / Y	1450	0,82	7,8/4,5	62,6/36,0	8,6/5,0	9,7/5,6	10,9/6,3	63	71
	2,2	4	60	2,5	265/460	D / Y	1740	0,82	7,8/4,5	60,1/34,6	8,6/5,0	9,7/5,6	10,9/6,3	On request	On request
		3	4	60	3,5	460	D	1740	0,78	6,4	49,8	7,0	8,0	9,0	On request
250	2,2	8	50	2,2	230/400	D / Y	725	0,66	10,2/5,9	55,1/31,9	11,2/6,5	12,8/7,4	14,3/8,3	47	54
		8	60	2,5	265/460	D / Y	870	0,66	10,2/5,9	52,9/30,6	11,2/6,5	12,8/7,4	14,3/8,3	On request	On request
	3	6	50	3,0	400/690	D / Y	965	0,74	6,8/3,9	40,8/23,4	7,5/4,3	8,6/4,9	9,6/5,5	53	61
		4	60	4,6	460	D	1160	0,74	9,0	58,8	9,9	11,3	12,6	On request	On request
250L	11	4	50	11,0	400/690	D / Y	1460	0,84	20,7/11,9	217,4/125,0	22,8/13,1	25,9/14,9	29,0/16,7	70	78

* IE3

Unless otherwise indicated, running and trip currents are valid for operation at rated voltage and a temperature of 60°C. Sound pressure levels are measured considering a free-field hemisphere with a radius of 1 meter, taken at the best efficiency point using the highest pitch angle impeller. **Lower pitch angle impellers will produce lower noise levels.**

For different working conditions and voltages, please contact EFAFLU.

Rated voltage tolerances:

50 Hz - +/- 10%

60Hz - +/- 5%



TGCL is an end suction radial type pump, from DN65 up to DN150, manufactured in EN-GJL-250 or EN-GJS-400 Cast iron with IP67 protection.

Maintenance free SKF bearings.

TGCL pumps operate with low noise levels, validated in our laboratory. The pumps come standard with C5H corrosion protection (according to ISO 12944). However, C5VH and CX are also available.

They can be installed horizontally or vertically, with the terminal box and drain/vent plugs positioned according to order, as the motor housing can be rotated in 90° increments. The flanges can be DIN or ISO PN10, raised or flat-faced. Due to a wide variety of motors (4P or 6P), they can meet the requirements of any project.

Part list

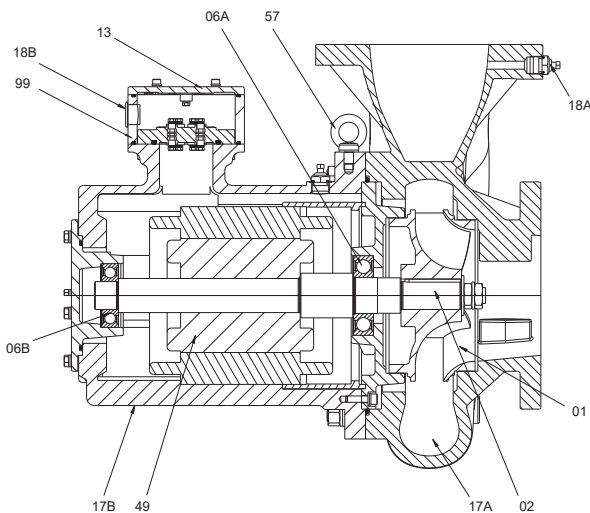

Characteristics

Specifications

Casing	EN-GJL-250 or EN-GJS-400
Impeller	EN-GJL-250 or EN-GJS-400
Shaft	AISI420
Terminal Box	Aluminium Al Si10 Mg
Fasteners	A4 – AISI316
IP	IP67
Optionals	ATEX (NTG 150) RAL / Munsell / British Standard C5VH / CX Raised face; Groove

Electrical data

Rated power	0,75 up to 7,5 kW
Poles	4/6
Voltages	3x400 VAC @ 50 Hz or 3x460 VAC @ 60 Hz

* Other voltages under request.

Part Designation

Part	Designation
01	Impeller
02	Shaft
06A	Bearing
06B	Bearing
13	Terminal box cover
17A	Pump casing
17B	Motor casing
18A	Drain/ vent
18B	Cable gland
49	Motor
57	Eye bolt
99	Terminal box

Mounting positions - horizontal and vertical

TGCL pumps can be mounted in different positions. The various mounting positions available can be simulated in PSO software. Some examples below (Other positions available).

1A1



2B2

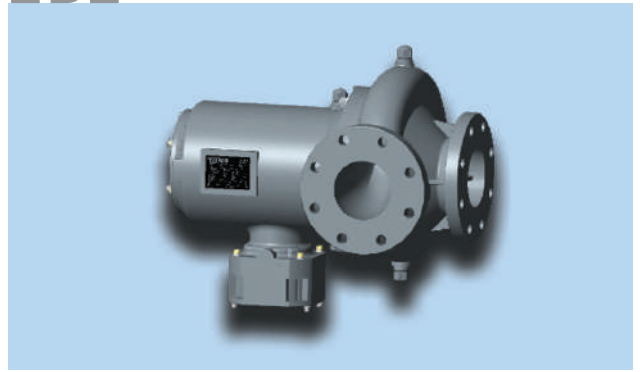

3A1



4C3

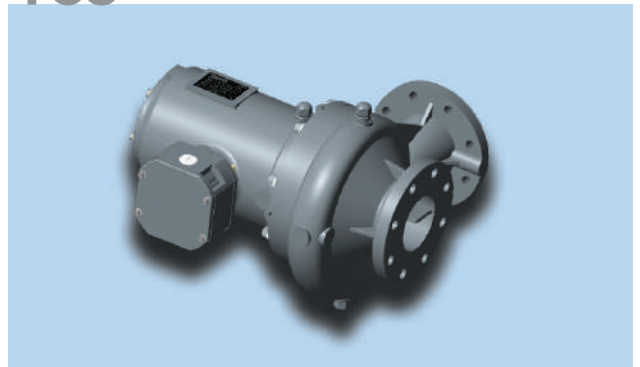

5A1



6D4



Curves According to ISO 9906 Grade 2B/ EN IEC 60076-22-5

50 Hz 400v

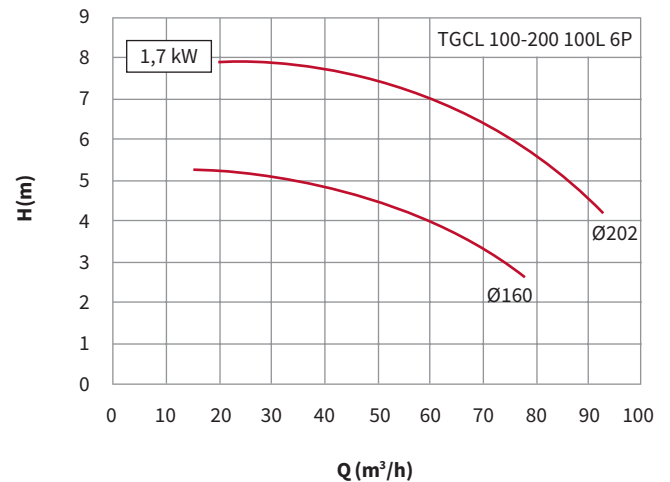
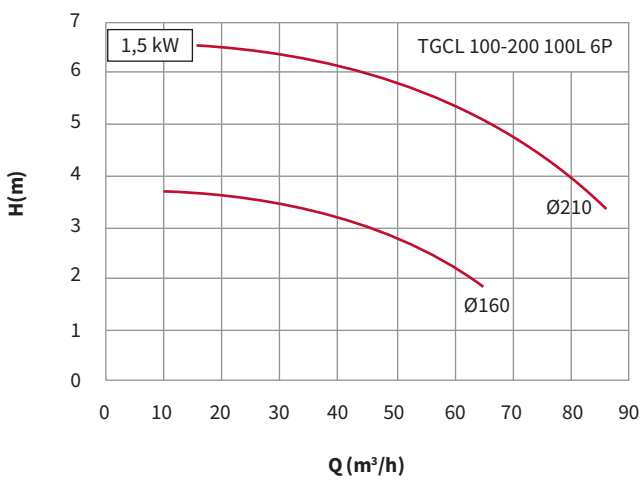
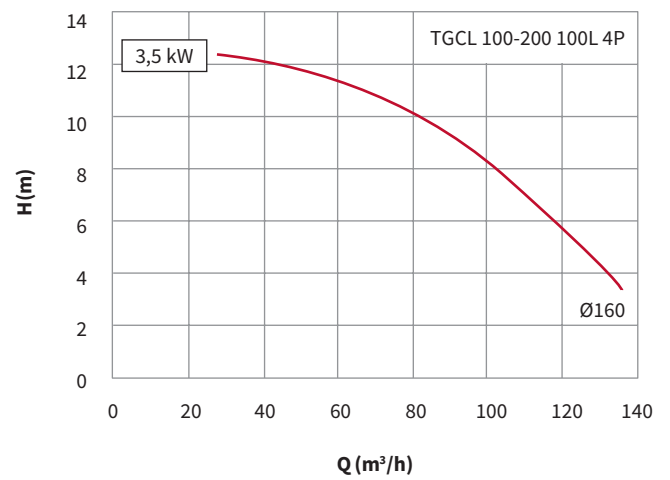
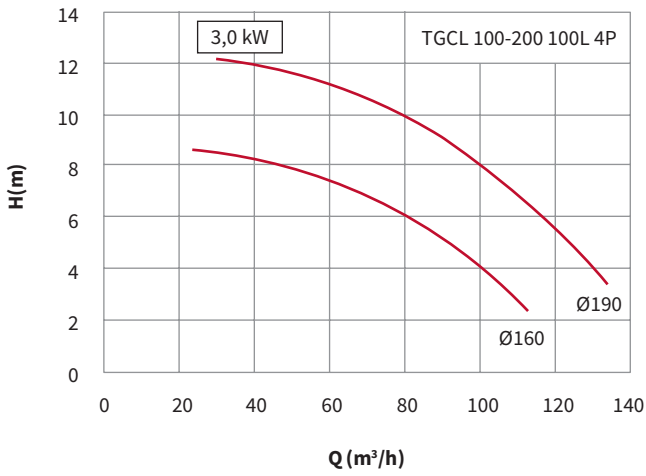
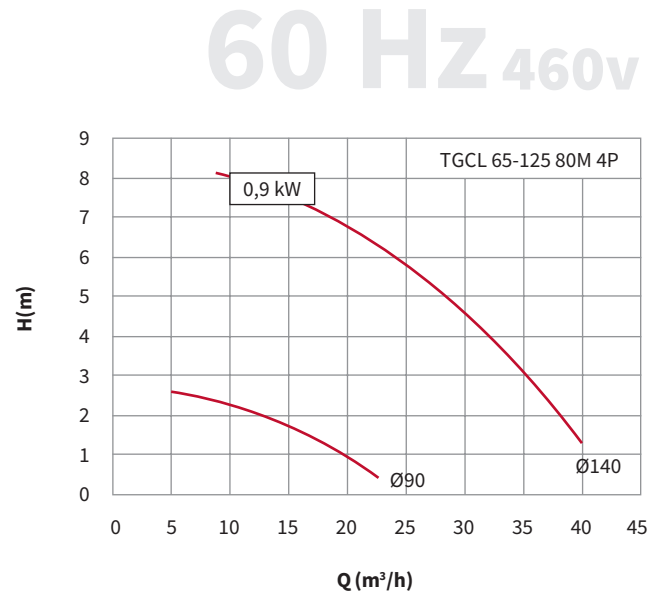
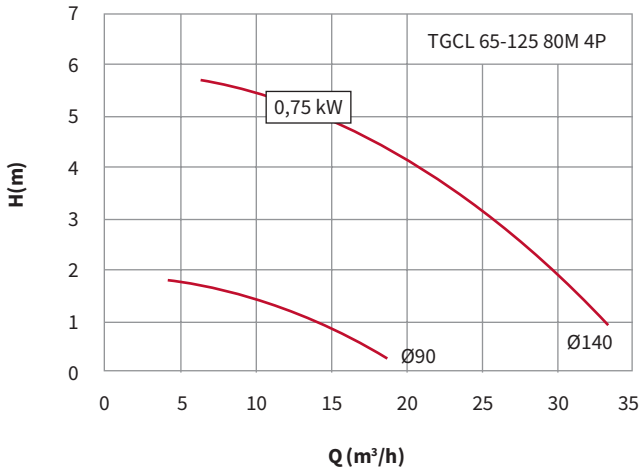

Curves According to ISO 9906 Grade 2B/ EN IEC 60076-22-5

50 Hz 400v

60 Hz 460v

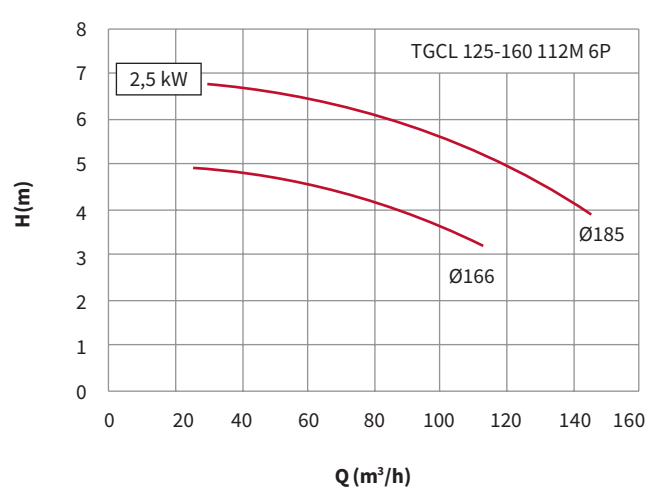
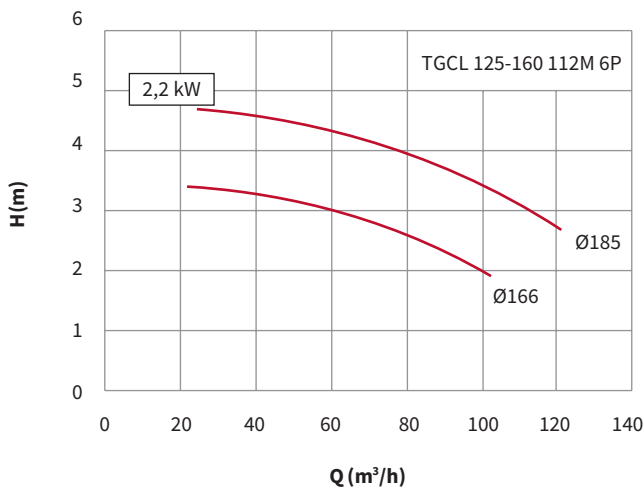
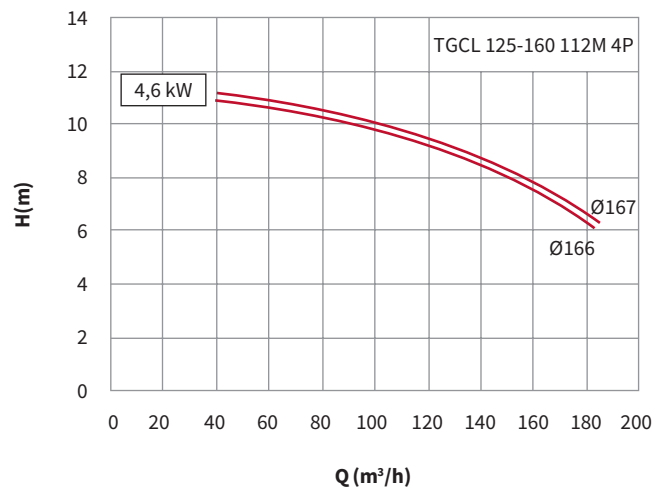
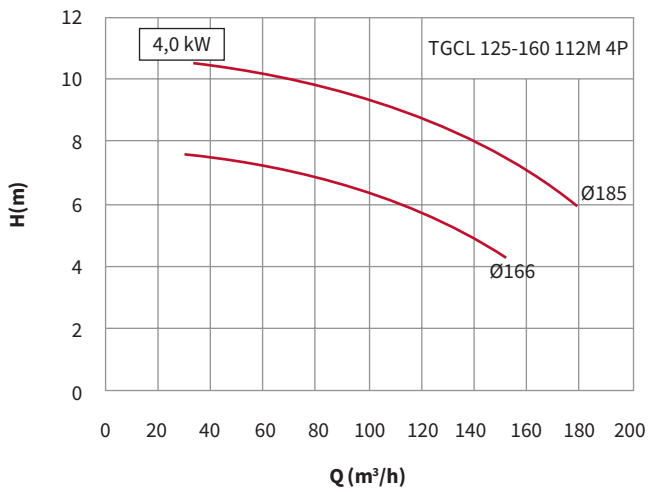
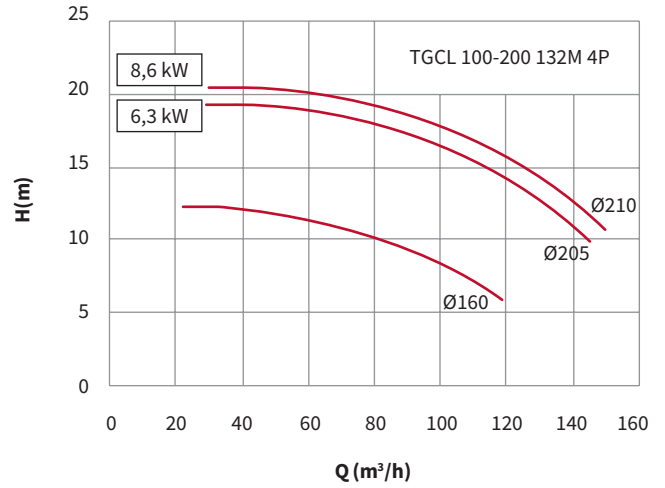
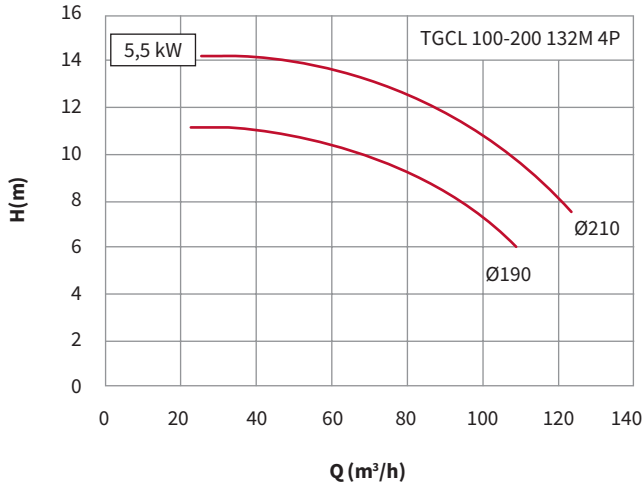

Curves According to ISO 9906 Grade 2B/ EN IEC 60076-22-5

50 Hz 400v

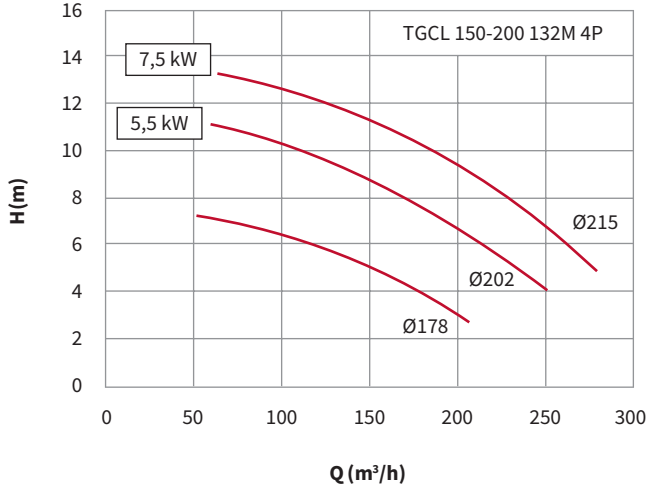

60 Hz 460v

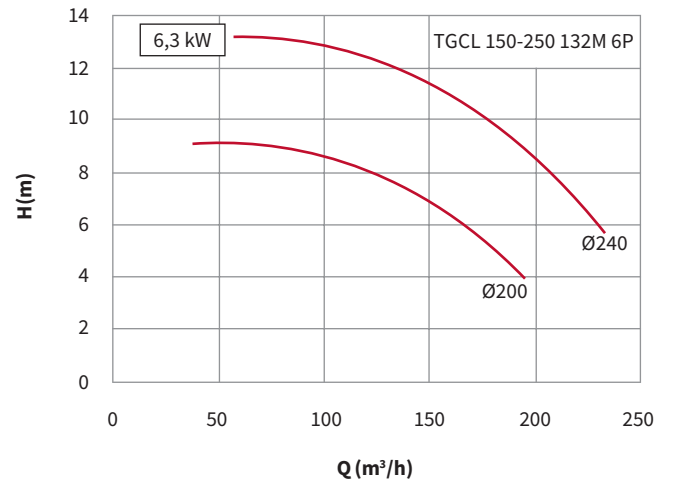
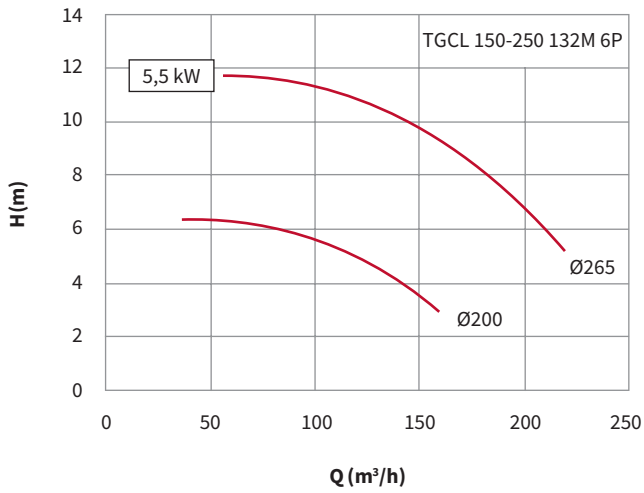
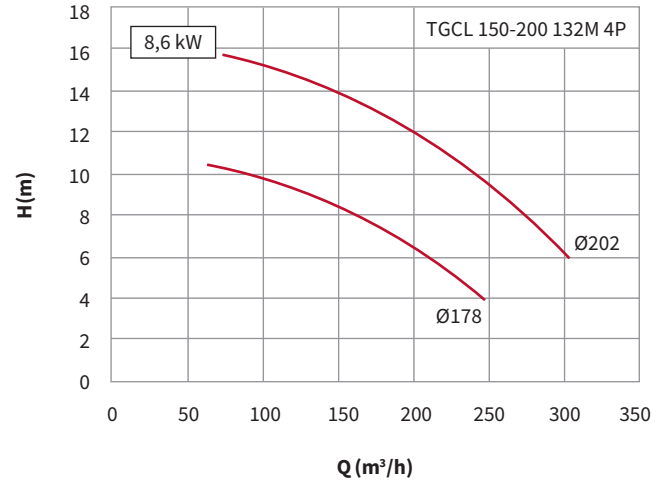

Dimensions (mm)

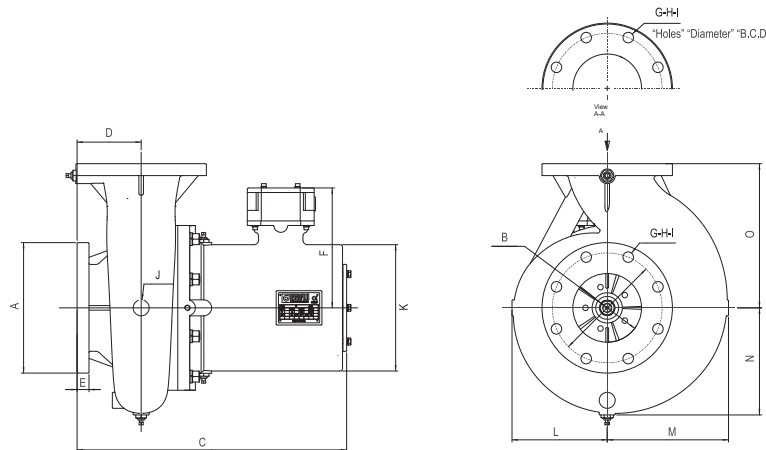

Pump	A	B	C	D	E	F	G	H	I	J	K	L	M	N	O	Weight (Kg)
TGCL 65-125 80M	185	65	392	86	18	204	4	18	145	35	171	113	121	113	150	55
TGCL 100-200 100L	220	100	524	125	24	234	8	18	180	35	211	155	188	173	250	120
TGCL 100-200 132M	220	100	559	125	24	260	8	18	180	35	276	180	188	180	250	160
TGCL 125-160 112M	250	125	559	125	26	245	8	18	210	35	235	181	221	202	280	145
TGCL 150-200 132M	285	150	589	140	26	260	8	23	240	35	276	208	265	234	315	195
TGCL 150-250 132M	285	150	574	140	26	260	8	23	240	35	276	211	262	237	355	190

Technical data

Model	Motor* (kW)	Poles	Frequency (Hz)	Rated Power (kW)	Voltage (V)	Connection	Rated Speed (rpm)	Power Factor	Rated Current (A)	Starting Current (A)	Trip Current (A)	Trip Current @ -10°C (A)	Trip Current @ -40°C (A)	SPL @ 1m (dBA)	SWL (dBA)
65-125 80M	0,75	4	50	0,75	230/400	D/Y	1430	0,7	3,3/1,9	20,8/12,0	3,6/2,1	4,2/2,4	4,7/2,7	42	50
		4	60	0,9	265/460	D/Y	1716	0,72	3,3/1,9	20,0/11,5	3,6/2,1	4,2/2,4	4,7/2,7	On request	On request
100-200 100L	1,5	6	50	1,5	230/400	D/Y	955	0,71	6,4/3,7	35,4/20,4	7,1/4,1	8/4,7	9,1/5,3	50	58
		6	60	1,7	265/460	D/Y	1146	0,71	3,7	34,0/19,5	7,1/4,1	8/4,7	9,1/5,3	On request	On request
	3	4	50	3,0	400/690	D/Y	1450	0,78	6,4/3,7	51,8/30,1	7,0/4,1	8/4,6	10,2/5,8	55	63
		4	60	3,5	460	D	1740	0,78	6,4	49,8	7,0	8/4,6	10,2/5,8	On request	On request
100-200 132M	5,5	4	50	5,5	400/690	D/Y	1460	0,84	10,5/6,1	94,5/54,8	11,6/6,7	13,2/7,7	14,7/8,5	58	66
		4	60	6,3	460	D	1752	0,84	10,5	90,7	11,6	13,2/7,7	14,7/8,5	On request	On request
125-160 112M	2,2	6	50	2,2	230/400	D/Y	960	0,72	9,7/5,6	53,6/30,8	10,7/6,2	12,2/7,0	13,6/7,8	42	50
		6	60	2,5	265/460	D/Y	1152	0,72	5,3	51,4/29,6	10,7/6,2	12,2/7,0	13,6/7,8	On request	On request
	4	4	50	4,0	400/690	D/Y	1450	0,82	8,0/4,6	68,8/39,9	8,8/5,1	10,0/5,8	11,2/6,4	60	68
		4	60	4,6	460	D	1740	0,82	8	66	8,8	10,0/5,8	11,2/6,4	On request	On request
150-200 132M	7,5	4	50	7,5	400/690	D/Y	1460	0,85	14,1/8,2	104,3/60,5	15,5/9,0	17,9/10,4	25,8/15	61	69
		4	60	8,6	460	D	1752	0,85	14,1	100,2	15,5	17,9/10,4	25,8/15	On request	On request
150-250 132M	5,5	6	50	5,5	400/690	D/Y	970	0,75	12,7/7,4	94,0/54,5	14,0/8,1	15,9/9,3	17,8/10,4	52	60
		6	60	6,3	460	D	1165	0,75	12,7	90,2	14,0	15,9/9,3	17,8/10,4	On request	On request

* IE3

Running and trip currents are valid for operation at rated voltage and temperature of 60°C. Sound pressure level measured considering a free field hemispherical surface with a radius of 1 meter at the best efficiency point, using the maximum diameter impeller. Lower diameter impellers will produce lower noise levels.

For different working conditions and other voltages please contact EFAFLU.

Rated voltage tolerances:

50Hz - ±10%

60Hz - ±5%

Fans

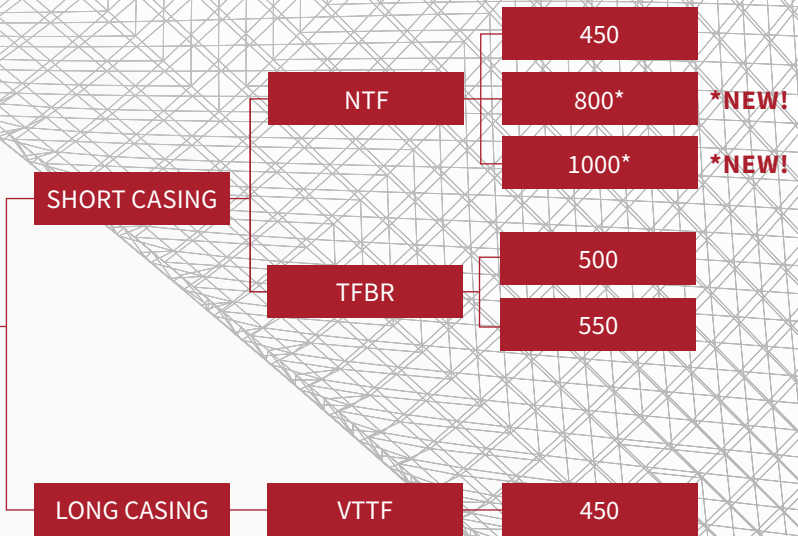

Our range offers an extensive variety of sizes and different design features that provide flexibility to our customers. We offer short and long casing solutions: NTF, TFBR, and VTTF, ranging from 450 mm up to 1000 mm, with a wide range of options. Our fans are designed and approved according to EN IEC 60076-22-6 and delivered to our customers with the certificate and test report. They are designed for use in radiators or air coolers according to EN IEC 60076-22-6 and can be supplied with various levels of corrosion protection, such as hot-dip galvanization or C5.

Range chart 50 Hz

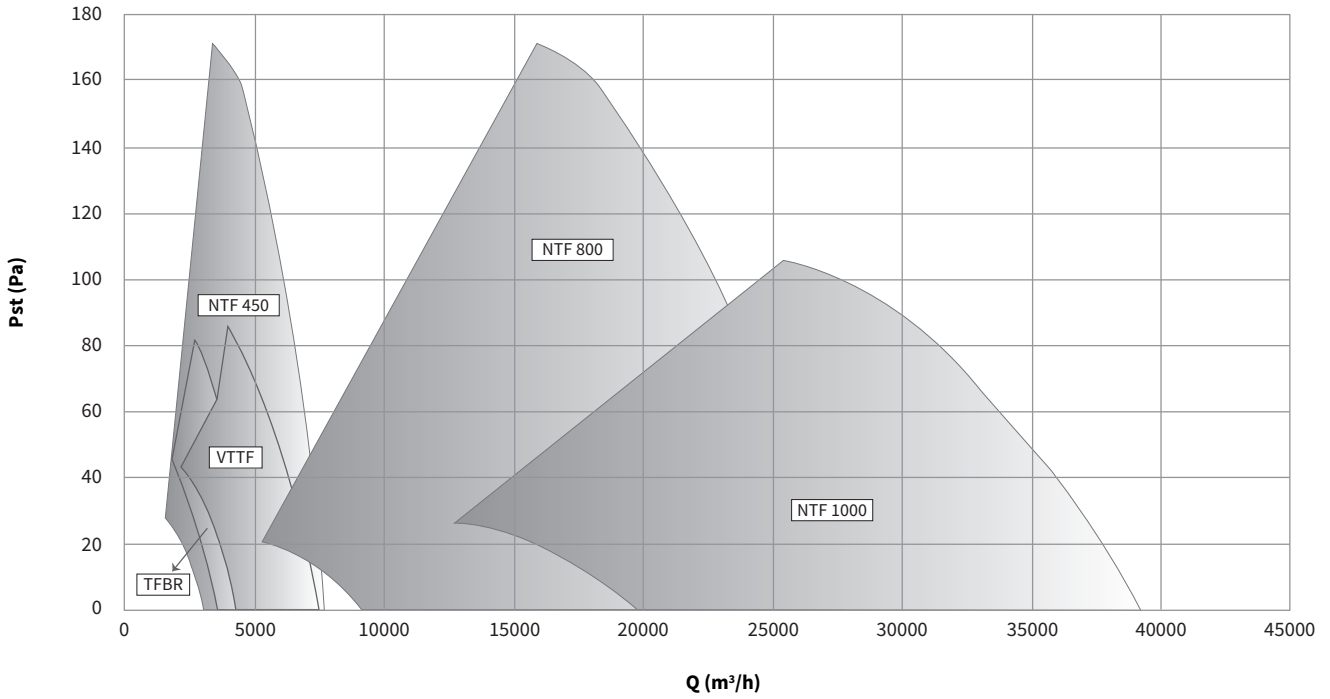

Fan model nomenclature

Fan size 450 500 550 800 1000	Blade profile	Impeller material PA: Polyamide A: Aluminium PAG: Glass fiber reinforced polyamide	Blade's pitch angle	Number of poles 4 6 8 10 12 16	Additional specifications N: Standard S: According to order
NTF 450 R / P1 / PA / 6 / 45 - 0,25 / 4 C5-M / N					
Series TFBR NTF VTF	Fan design R: Round S: Square L: Long		Number of blades	Rated power 0,09 0,12 0,18 0,25 0,37 0,55 0,75 1,1 1,5 2,2	Surface treatment C5-M: Coating system C5-H: Coating system Z: Hot dip galvanization

Applications

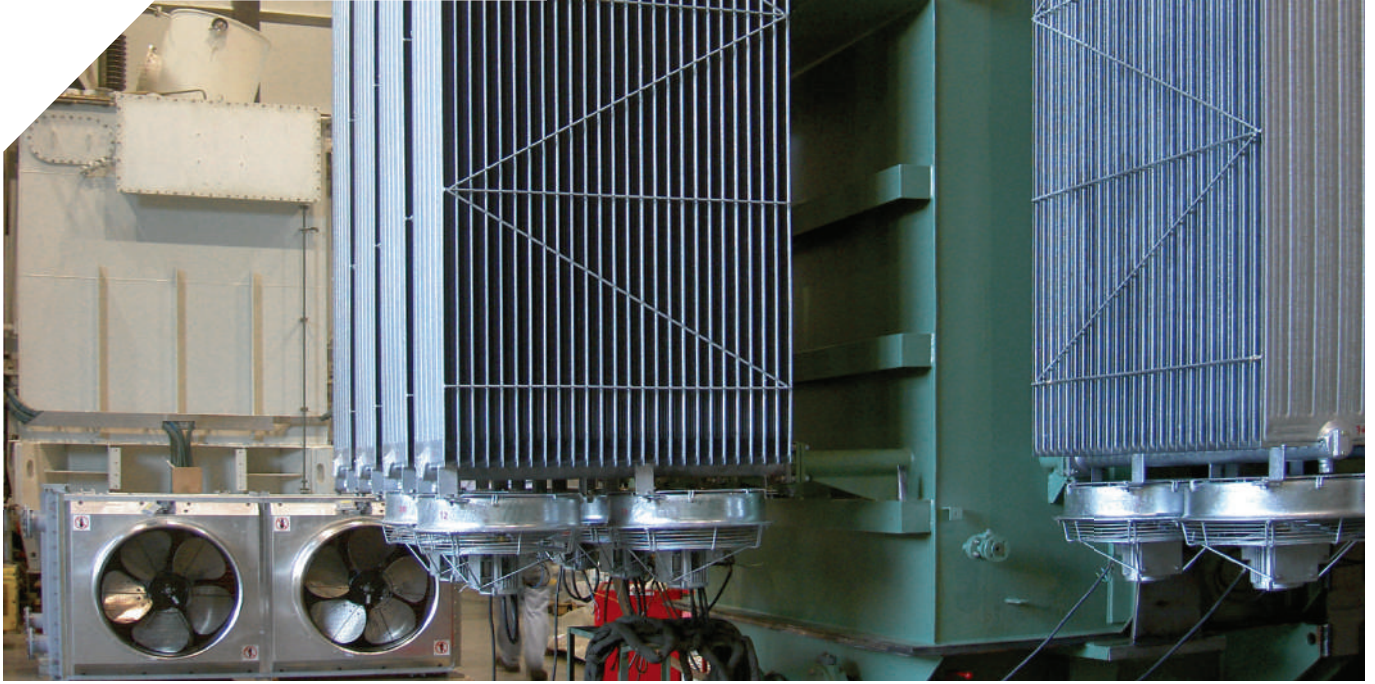



NTF is a 450, 800 and 1000 mm short casing type fan, with a carbon steel casing and an electric motor with IP56 protection.

The impeller is made from either casted aluminium or glass fiber reinforced polyamide and the fan is supplied with back and front grid protection. It can be supplied with hot dip galvanization or with C5 surface protection, along with AISI 316 (A4) fasteners.

NTF can be installed horizontally or vertically, according to the transformer layout.

Standard supply:

Painted version with motor painted in RAL 7035. For galvanized solutions, the motor is painted in RAL 9006.

Ambient temperature -30 a 50°C according to datasheets.

Characteristics

	Specifications
Casing	Carbon Steel
Impeller	Casted Aluminium/ Polyamide/ Glass fiber reinforced polyamide
Terminal Box	IP56
Fasteners	A4 – AISI316
Protection grill	AISI316 L
Optionals	Ambient temperatures -45 to 50°C Entire fan painted with the same RAL Other RAL solutions Other voltages and frequencies Other IP: IP66 Tropicalized winding

Electrical data

Rated power	0,09/ 0,12/ 0,18/ 0,25/ 0,37/ 0,55/ 0,75/ 1,1/ 1,5/ 2,2 kW
Poles	4/ 6/ 8/ 10/ 12/ 16
Voltages	3x230/400 VAC @ 50 Hz or 3x265/460 VAC @ 60 Hz

Part list

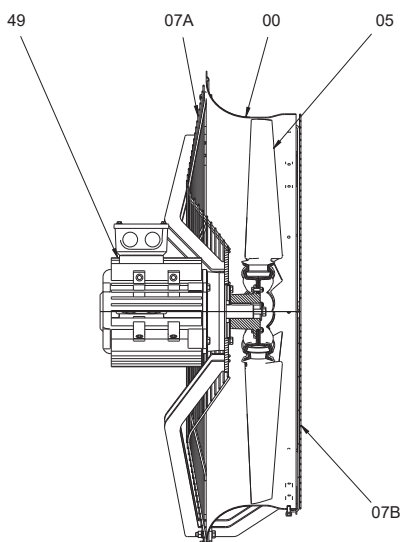

Part	Designation
00	Fan casing
05	Impeller
07A	Inlet protection grid
07B	Outlet protection grid
49	Motor

Dimensions (mm)

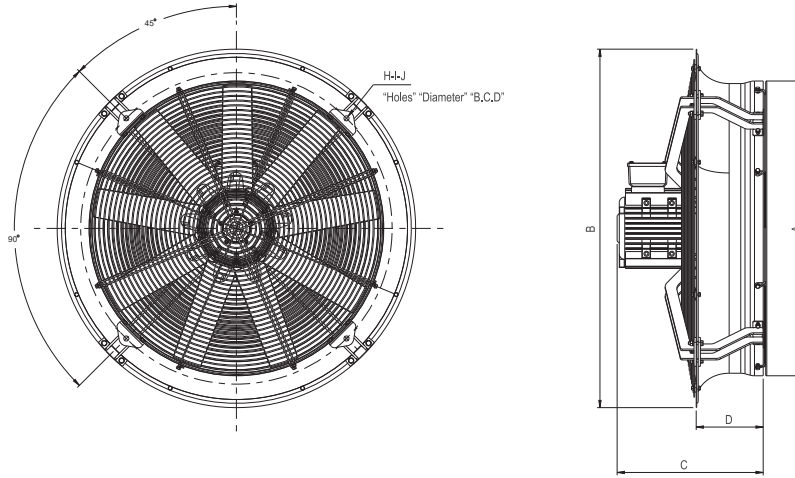

Fan	A	B	C	D	H	I	J
NTF 450	489	598	305	121	8	14	520
NTF 800	814	990	438	197	4	14	889
NTF 1000	1016	1170	585	214	4	14	1092

Technical data (400 Y/230Δ)

Range	ID	Model	Nr. Poles	Fan speed RPM	Frequency [Hz]	P2 [kW]	I _{NOMINAL} [A]	I _{START} [A]	I _{TRIP} [A]	QMAX [m3/h]	SPLA @ 2m [dB]	LwA [dB]	Weight [kg]
STANDARD	1	NTF 450R/P1/PA/6/35 - 0,09/8	8	730	50	0,09	0,58 / 1	1,33 / 2,31	0,64 / 1,11	3050	50	64	13
	2	NTF 450R/P1/PA/6/35 - 0,12/6	6	910	50	0,12	0,51 / 0,88	1,38 / 2,39	0,56 / 0,97	4000	55	69	13
	3	NTF 450R/P1/PA/6/45 - 0,12/6	6	910	50	0,12	0,51 / 0,88	1,38 / 2,39	0,56 / 0,97	4900	58	72	13
	4	NTF 450R/P1/PA/6/35 - 0,18/4	4	1390	50	0,18	0,55 / 0,95	1,98 / 3,43	0,61 / 1,05	6400	64	78	13
	5	NTF 450R/P1/PA/6/45 - 0,37/4	4	1390	50	0,37	1,01 / 1,75	4,75 / 8,22	1,11 / 1,92	7650	69	83	13
HIGH AIR FLOW	1	NTF 800R/P2/PAG/9/45 - 0,25/16	16	350	50	0,25	1,44 / 2,49	3,6 / 6,24	1,58 / 2,74	10100	51	65	47
	2	NTF 800R/P2/PAG/9/45 - 0,37/12	12	470	50	0,37	2,1 / 3,64	5,88 / 10,18	2,31 / 4,00	13500	57	71	47
	3	NTF 800R/P2/PAG/9/45 - 0,55/10	10	570	50	0,55	2,4 / 4,16	8,16 / 14,13	2,64 / 4,57	16400	62	76	55
	4	NTF 800R/P2/PAG/9/45 - 1,1/8	8	700	50	1,1	3,01 / 5,21	12,94 / 22,42	3,31 / 5,73	20200	66	80	47
	5	NTF 800R/P2/PAG/9/45 - 2,2/6	6	960	50	2,2	5,54 / 9,6	30,47 / 52,78	6,09 / 10,56	27700	74	88	55
LOW NOISE	1	NTF 800R/P2/PAG/7/43,5 - 0,25/16	16	350	50	0,25	1,44 / 2,49	3,6 / 6,24	1,58 / 2,74	9170	49	63	47
	2	NTF 800R/P2/PAG/7/43,5 - 0,25/12	12	470	50	0,25	1,5 / 2,6	4,2 / 7,27	1,65 / 2,86	12300	56	70	47
	3	NTF 800R/P2/PAG/7/43,5 - 0,55/10	10	570	50	0,55	2,4 / 4,16	8,16 / 14,13	2,64 / 4,57	14900	60	74	55
	4	NTF 800R/P2/PAG/7/43,5 - 1,1/8	8	700	50	1,1	3,01 / 5,21	12,94 / 22,42	3,31 / 5,73	18300	64	78	47
	5	NTF 800R/P2/PAG/7/43,5 - 2,2/6	6	960	50	2,2	5,54 / 9,6	30,47 / 52,78	6,09 / 10,56	25200	71	85	55
HIGH AIR FLOW	1	NTF 1000R/P4/PAG/9/53,5 - 0,55/16	16	365	50	0,55	3 / 5,2	8,1 / 14,03	3,3 / 5,72	21400	54	68	95
	2	NTF 1000R/P4/PAG/9/53,5 - 0,75/12	12	475	50	0,75	3,4 / 5,89	11,56 / 20,02	3,74 / 6,48	27800	62	76	79
	3	NTF 1000R/P4/PAG/9/53,5 - 1,5/10	10	585	50	1,5	5,5 / 9,53	19,8 / 34,29	6,05 / 10,48	34300	69	83	95
LOW NOISE	1	NTF 1000R/P4/PAG/7/53,5 - 0,55/16	16	365	50	0,55	3 / 5,2	8,1 / 14,03	3,3 / 5,72	19800	52	66	94
	2	NTF 1000R/P4/PAG/7/53,5 - 0,75/12	12	475	50	0,75	3,4 / 5,89	11,56 / 20,02	3,74 / 6,48	25700	60	74	78
	3	NTF 1000R/P4/PAG/7/53,5 - 1,5/10	10	585	50	1,5	5,5 / 9,53	19,8 / 34,29	6,05 / 10,48	31700	65	79	94
	4	NTF 1000R/P4/PAG/7/53,5 - 2,2/8	8	725	50	2,2	5,87 / 10,17	31,7 / 54,9	6,46 / 11,18	39200	71	85	78

Note: Aerodynamic and acoustic tests according to standards ISO 5801 and ISO 13347-1,3 with protection net on suction and pressure side. Values shown above are subjected to tolerances according to ISO 13348 (AN3).

* Considering hemispherical measuring surface with a radius of 2 meters.

Other solutions beyond those shown in the table above can be considered depending on project requirements (please contact export@efalu.pt for more information).

Curves (50 Hz)

Standard range

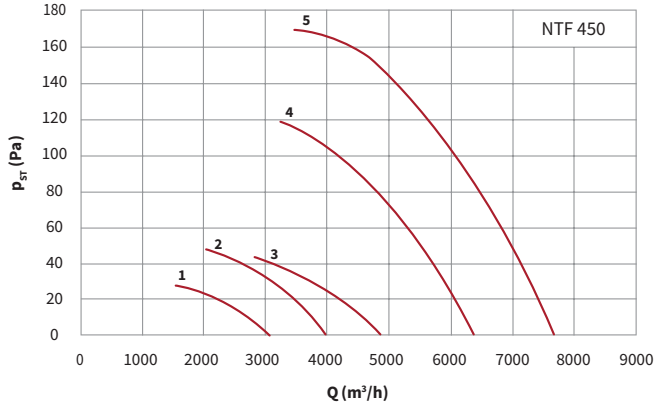

Low Noise

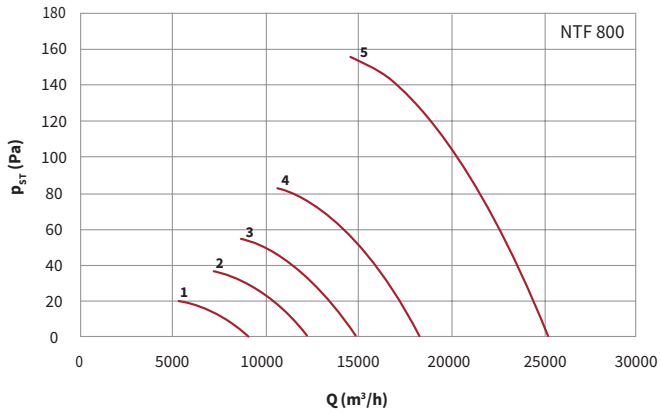

High Airflow

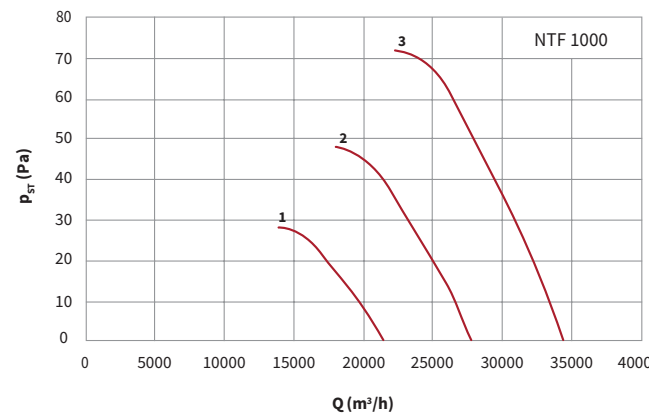
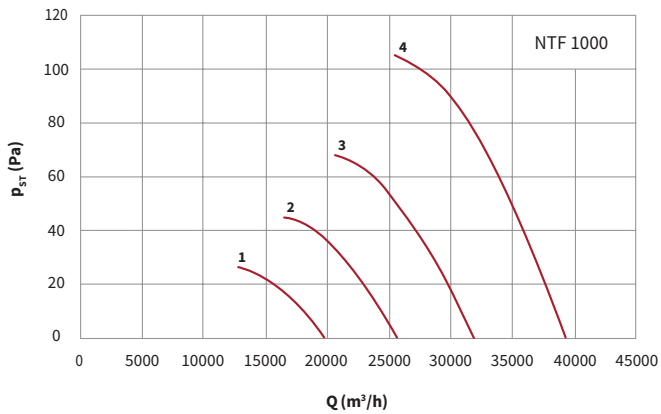
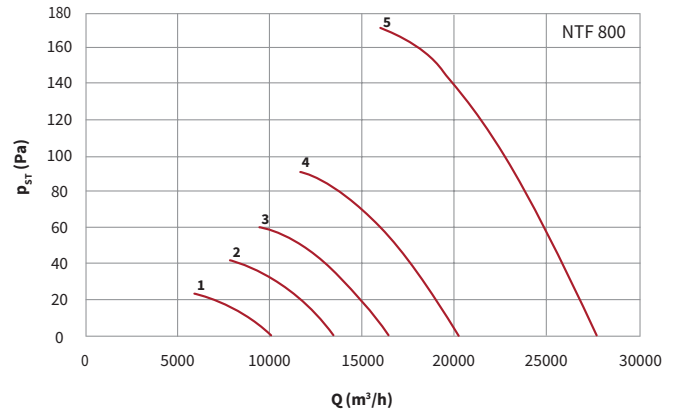



TFBR is a 500 and 550 mm short casing type fan with low noise design conception, with a carbon steel casing and an electric motor with IP56 protection.

The impeller is made from stamped aluminium and the fan is supplied with back and front grid protection. It can be supplied with various levels of corrosion protection, such as hot-dip galvanization or C5, along with AISI 316 (A4) fasteners. TFBR can be installed horizontally or vertically, according to the transformer layout.

Part list

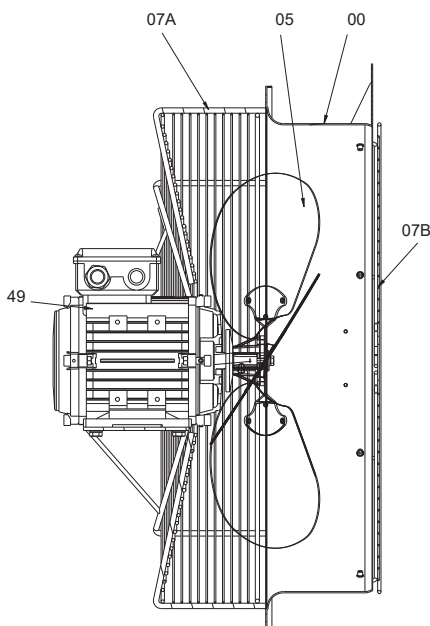

Characteristics

Specifications

Casing	Carbon Steel
Impeller	Stamped Aluminium
Fasteners	A4 – AISI316
IP	IP56
Optionals	Ambient temperatures -50 to 50°C Entire fan painted with the same RAL Other RAL solutions Other voltages and frequencies Other IP: IP66 Tropicalized winding

Electrical data

Rated power	0,18 up to 0,37 kW
Poles	6/8
Voltages	3x400 VAC @ 50 Hz or 3x460 VAC @ 60 Hz

Part Designation

Part	Designation
00	Fan casing
05	Impeller
07A	Inlet protection grid
07B	Outlet protection grid
49	Motor

Dimensions (mm)

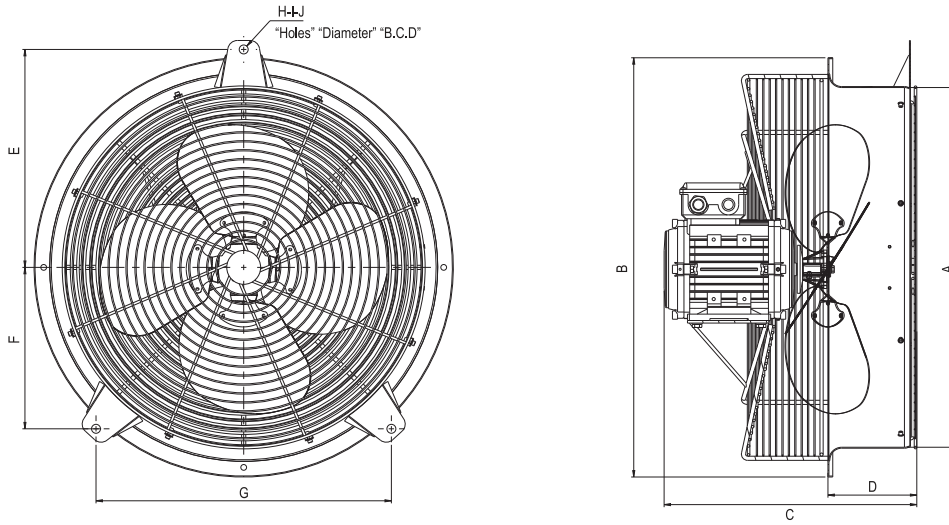

Fan	A	B	C	D	E	F	G	H	I	J
TFBR 500	518	595	370	141	301	203	443	3	14	601
TFBR 550	562	655	380	138	341	252	462	3	14	682

Technical data

Model	ID	Frequency (Hz)	Flow (m³/h)	Static pressure (Pa)	Fan speed (rpm)	Nominal Power (kW)	Nr. Poles	SPL at 2m [dB(A)]	SWL (dBA)	Weight (Kg)
TFBR 500R/P5/A/4/27 - 0,18/8	1	50	4300	0 (free air)	675	0,18	8	50	64,0	19
TFBR 550R/P5/A/4/27 - 0,18/8	2	50	6320	0 (free air)	690	0,18	8	51	65,0	20
TFBR 550R/P5/A/4/27 - 0,37/6	3	50	7500	0 (free air)	900	0,37	6	60	74,0	20

Note: Other solutions beyond those shown in the table above can be considered depending on project requirements (please contact export@efafllu.pt for more information).
Aerodynamic and acoustic test according to standards ISO 5801 and ISO 13347-1,3 with protection net on suction and pressure side.
Values shown above are subjected to tolerances according to ISO 13348 (AN3).

Curves (50 Hz)

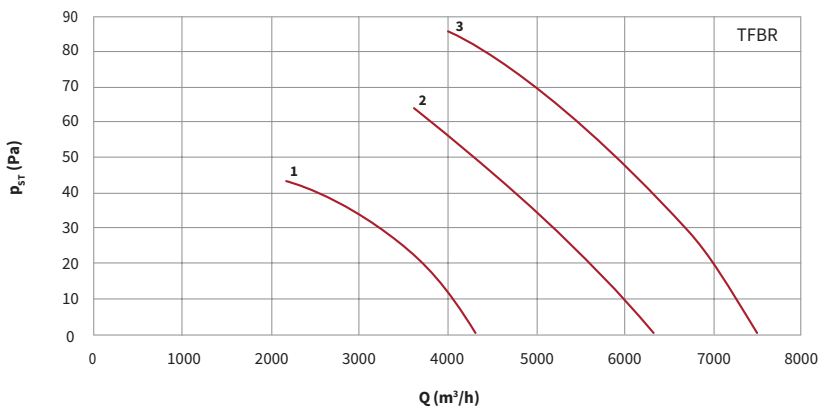



Characteristics

VTTF is a 450 mm long casing type fan, where the motor is inside the fan housing, thus more protected from outside environment conditions. With a carbon steel casing and an electric motor with IP56 protection.

The impeller is made from stamped aluminium or glassfiber reinforced polyamide and the fan is supplied with back and front grid protection. It can be supplied with various levels of corrosion protection, such as hot-dip galvanization or C5, along with AISI 316 (A4) fasteners. VTTF can be installed horizontally or vertically, according to the transformer layout.

Specifications

Casing	Carbon Steel
Impeller	Stamped Aluminium/ Glass fiber reinforced polyamid
Fasteners	A4 – AISI316
IP	IP56
Optionals	Ambient temperatures -50 to 50°C Entire fan painted with the same RAL Other RAL solutions Other voltages and frequencies Other IP: IP66 Tropicalized winding

Part list

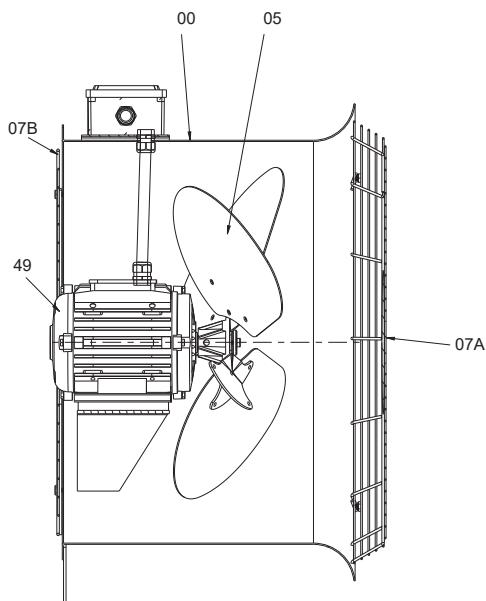

Electrical data

Rated power	0,18/ 0,25 kW
Poles	6
Voltages	3x230/400 VAC @ 50 Hz or 3x265/460 VAC @ 60 Hz

Part Designation

00	Fan casing
05	Impeller
07A	Inlet protection grid
07B	Outlet protection grid
49	Motor

Dimensions (mm)

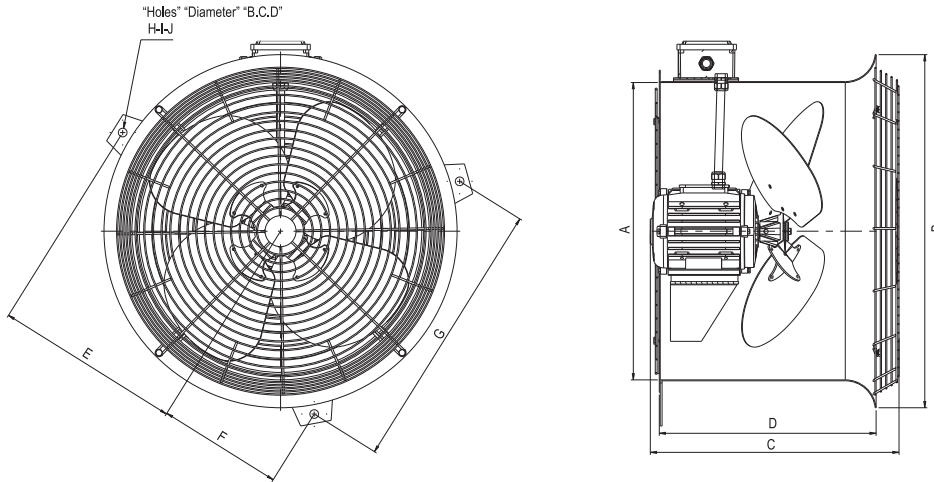

Fan	A	B	C	D	E	F	G	H	I	J
VTTF 450	480	570	400	350	301	203	443	3	14	601

Technical data

Model	ID	Frequency (Hz)	Flow (m³/h)	Static pressure (Pa)	Fan speed (rpm)	Nominal Power (kW)	Nr. Poles	SPL at 2m [dB(A)]	SWL (dBA)	Weight (Kg)
VTTF 450L/P6/PAG/6/40-0,25/6	1	50	5300	0 (free air)	910	0,25	6	52	66,0	19
VTTF 450L/P5/A/4/27 - 0,18/6	2	50	3600	0 (free air)	850	0,18	6	50	64,0	18

Note: Other solutions beyond those shown in the table above can be considered depending on project requirements (please contact export@efafllu.pt for more information).
Aerodynamic and acoustic test according to standards ISO 5801 and ISO 13347-1,3 with protection net on suction and pressure side.
Values shown above are subjected to tolerances according to ISO 13348 (AN3).

Curves (50 Hz)

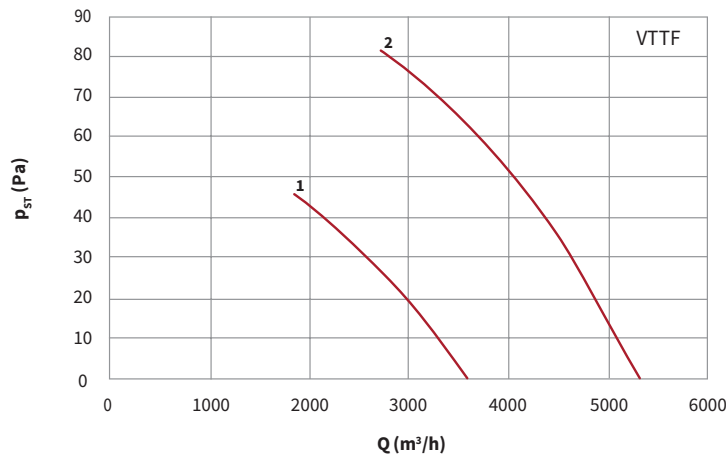

Product Selector Online

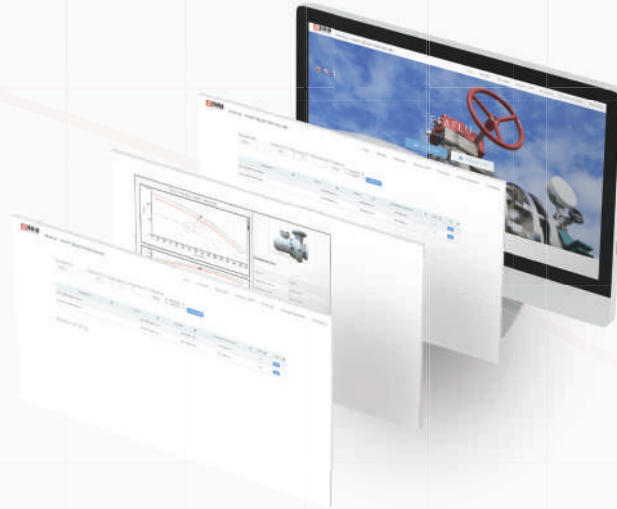

With EFAFLU's online pump selector, you can:

- » Select the most suitable equipment for your projects.
- » See a 3D model of your pump according to your needs.

Access

pso.efaflu.pt

or scan this code:



Other solutions by request

- » Cooling fans totally designed according to our client needs;
- » Other flows (fans);
- » Special casing treatments (painting, powder coating);
- » Cable connectors;
- » Flexible mounting solutions;
- » Single-phase electric motors;
- » Different voltages and frequencies;
- » Different gasket materials according to fluid and temperature conditions;
- » Different IP protection grades;
- » PT 100;
- » Harting connector;



Technical Assistance EFAFLU

[+351] 252 298 712

[+351] 964 241 072

sav@efafllu.pt



Technical assistance



Multibrand service



Maintenance contracts



On-site repairs



Energy efficiency



Spare parts

After-Sales Services and Commissioning

Our after sales services relies on experienced field engineers that will provide our client the best solutions at the least possible time. We offer full availability to diagnose, evaluate and solve problems at the client's requested location. We keep in store original spare parts for 20 years ensuring a fast and reliable maintenance, and a long lasting product. Our commitment does not end with the delivery of the equipment. We offer a full customer support during the installation and startup, along with precise instructions for safe and correct use. We want our client to benefit the most from our services, adding value to the business chain.



ANEPC

EMPRESA REGISTADA N°458

APSEI

ASSOCIAÇÃO PORTUGUESA DE SEGURANÇA

EMPRESA ASSOCIADA N° 271

SRPCBA

EMPRESA REGISTADA N° RE-67/RAA

EFAFLU

CT 050/05.05 EN 09/2024

EFAFLU is a Portuguese company with more than 75 years of experience, entirely dedicated to development, manufacture, marketing, technical support as well as after-sales service of pumps, pumping systems, fans and generating sets. Our products are distributed throughout Portugal and abroad by specialized and qualified partners.

HEAD OFFICE Póvoa de Varzim, Portugal

T [+351] 252 298 700

geral@efafllu.pt

export@efafllu.pt

LISBON OFFICE Cacém, Portugal

T [+351] 214 134 700

vendassul@efafllu.pt

AFTER-SALES SERVICES

T [+351] 252 298 712

sav@efafllu.pt

EFAFLU UK

T [+44] 151 523 4765

enquiries@efafllu.co.uk

www.efafllu.pt

www.efafllu.co.uk