

BMVE (T/Ti) Pompes multicellulaires | Bombas multietapa verticales

➤ APPLICATIONS

Systèmes d'irrigation sous pression
Fertilisation et dosage
Approvisionnement domestique et public
Systèmes de traitement d'eau
Approvisionnement de chaudières
Services industriels
Équipements de lavage

➤ MATÉRIAUX DE CONSTRUCTION

Corps d'aspiration et de décharge: Fonte
Roue: AISI 304
Diffuseur: AISI 304
Arbre: AISI 304
Garniture: Mécanique en Car/ WC/ EPDM
O'rings: Viton
Remarques: AISI 304 et 316 version complète disponible

➤ LIMITES D'UTILISATION

Température du liquide: jusqu'à 120°C
Pression nominale: 25 bar
Température maximale de l'environnement: 40°C

➤ CARACTÉRISTIQUES DU MOTEUR

Tension: 3x400V
Classe d'isolation: F
Classe de protection: IP55
Rotation: 2900 rpm

➤ APLICACIONES

Sistemas de riego a presión
Fertilización y dosificación
Suministro doméstico y público
Sistemas de tratamiento de agua
Suministro de calderas
Servicios industriales
Equipos de lavado

➤ MATERIALES DE CONSTRUCCIÓN

Cuerpo de aspiración y descarga: Hierro fundido
Impulsor: AISI 304
Difuser: AISI 304
Eje: AISI 304
Sello: Mecánico en Car/ WC/ EPDM
O'rings: Viton
Notas: Disponible en versión completa AISI 304 y 316

➤ LÍMITES DE USO

Temperatura del líquido: hasta 120°C
Presión nominal: 25 bar
Temperatura máxima del ambiente: 40°C

➤ CARACTERÍSTICAS DEL MOTOR

Tensión: 3x400V
Clase de aislamiento: F
Clase de protección: IP55
Rotación: 2900 rpm

Remarque: Cette gamme de pompes est également disponible en version monophasée (1x230V) ou avec des moteurs à 4 pôles. Pour la sélection, veuillez contacter nos services techniques.

Nota: Esta gama de Pompes también está disponible en versión monofásica (1x230V) o con motores de 4 polos. Para la selección, póngase en contacto con nuestros Servicios Técnicos.



BMVE (T/Ti)

Les pompes de la série **BMVE (T/Ti)** sont des pompes verticales multicellulaires en ligne à haut rendement, robustes et extrêmement silencieuses. Ils présentent des caractéristiques adaptées au pompage de l'eau propre ainsi qu'aux applications industrielles.

La serie **BMVE (T/Ti)** son bombas verticales multietapa en línea de alto rendimiento, robustas y extremadamente silenciosas. Tienen características adecuadas para el bombeo de agua limpia, así como para aplicaciones industriales.

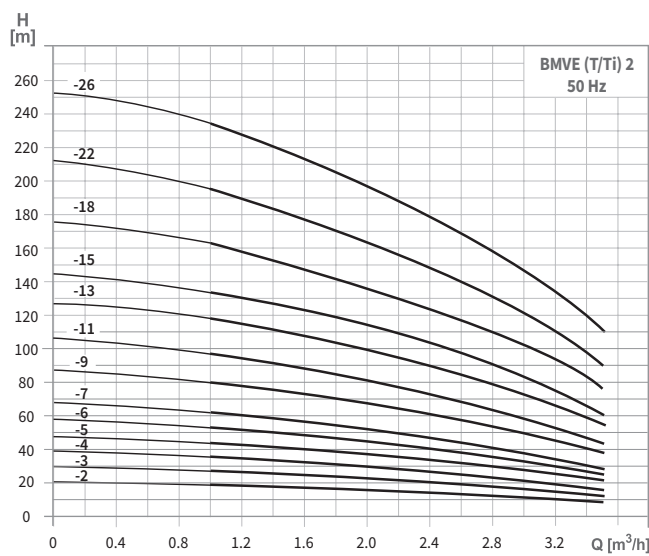

BMVE 2
DN 25

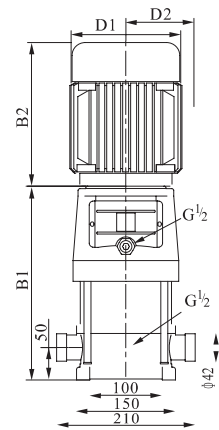

Flange
DIN

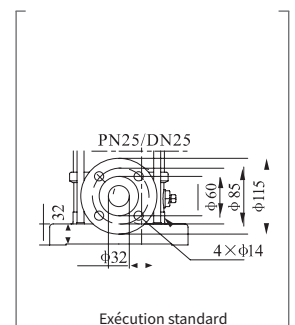

Exécution standard
Ejecución normalizada

MODÈLE MODELO	PUISSANCE POTENCIA (kW)	DIMENSIONS DIMENSIONES (mm)					POIDS PESO (Kg)
		B1	B2	B1+B2	D1	D2	
BMVE (T/Ti) 2-2	0,37	233	210	443	148	117	20
BMVE (T/Ti) 2-3	0,37	251	210	461	148	117	20
BMVE (T/Ti) 2-4	0,55	269	210	479	148	117	22
BMVE (T/Ti) 2-5	0,55	287	210	497	148	117	23
BMVE (T/Ti) 2-6	0,75	315	245	560	170	142	26
BMVE (T/Ti) 2-7	0,75	333	245	578	170	142	26
BMVE (T/Ti) 2-9	1,1	369	245	614	170	142	28
BMVE (T/Ti) 2-11	1,1	405	245	650	170	142	29
BMVE (T/Ti) 2-13	1,5	451	290	741	190	155	35
BMVE (T/Ti) 2-15	1,5	487	290	777	190	155	36
BMVE (T/Ti) 2-18	2,2	541	290	831	190	155	41
BMVE (T/Ti) 2-22	2,2	613	290	903	190	155	42
BMVE (T/Ti) 2-26	3,0	695	315	1010	197	165	52

Brides ovales disponibles sur demande
Bridas ovaladas disponibles bajo pedido

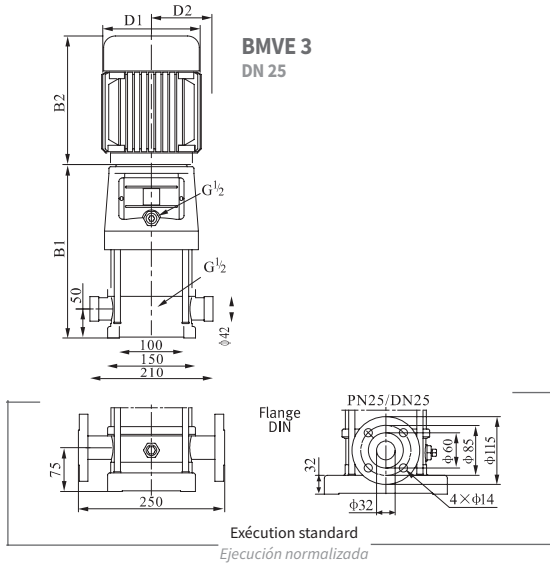
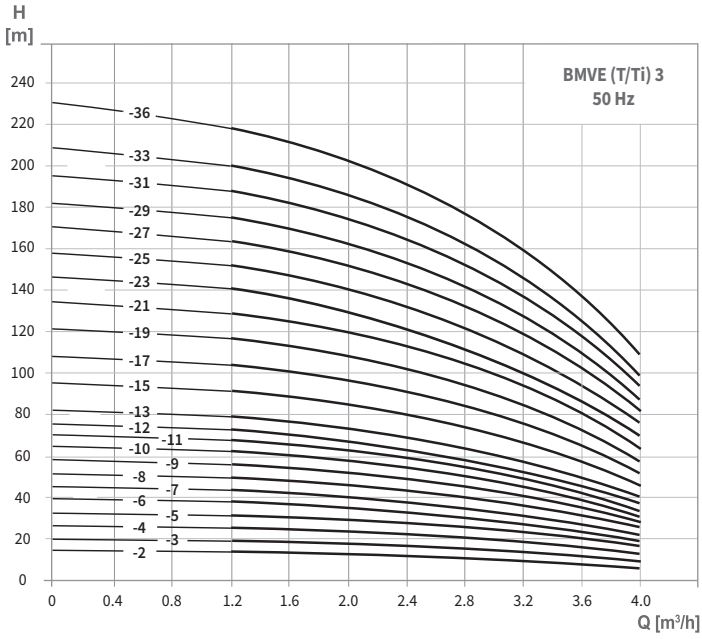

MODÈLE MODELO	PUISSANCE POTENCIA (kW)	DIMENSIONS DIMENSIONES (mm)					POIDS PESO (KG)
		B1	B2	B1+B2	D1	D2	
BMVE (T/Ti) 3-2	0,37	233	210	443	148	117	20
BMVE (T/Ti) 3-3	0,37	251	210	461	148	117	20
BMVE (T/Ti) 3-4	0,37	269	210	479	148	117	21
BMVE (T/Ti) 3-5	0,37	287	210	497	148	117	21
BMVE (T/Ti) 3-6	0,55	305	210	515	148	117	23
BMVE (T/Ti) 3-7	0,55	323	210	533	148	117	24
BMVE (T/Ti) 3-8	0,75	351	245	596	170	142	27
BMVE (T/Ti) 3-9	0,75	369	245	614	170	142	28
BMVE (T/Ti) 3-10	0,75	387	245	632	170	142	28
BMVE (T/Ti) 3-11	1,1	405	245	650	170	142	29
BMVE (T/Ti) 3-12	1,1	423	245	668	170	142	30
BMVE (T/Ti) 3-13	1,1	441	245	686	170	142	31
BMVE (T/Ti) 3-15	1,1	477	245	722	170	142	32
BMVE (T/Ti) 3-17	1,5	523	290	813	190	155	38
BMVE (T/Ti) 3-19	1,5	559	290	849	190	155	39
BMVE (T/Ti) 3-21	2,2	595	290	885	190	155	42
BMVE (T/Ti) 3-23	2,2	631	290	921	190	155	43
BMVE (T/Ti) 3-25	2,2	692	290	982	190	155	44
BMVE (T/Ti) 3-27	2,2	728	290	1018	190	155	45
BMVE (T/Ti) 3-29	2,2	764	290	1054	190	155	46
BMVE (T/Ti) 3-31	3,0	810	315	1125	197	165	54
BMVE (T/Ti) 3-33	3,0	846	315	1161	197	165	55
BMVE (T/Ti) 3-36	3,0	900	315	1215	197	165	57

Brides ovales disponibles sur demande
Bridas ovaladas disponibles bajo pedido

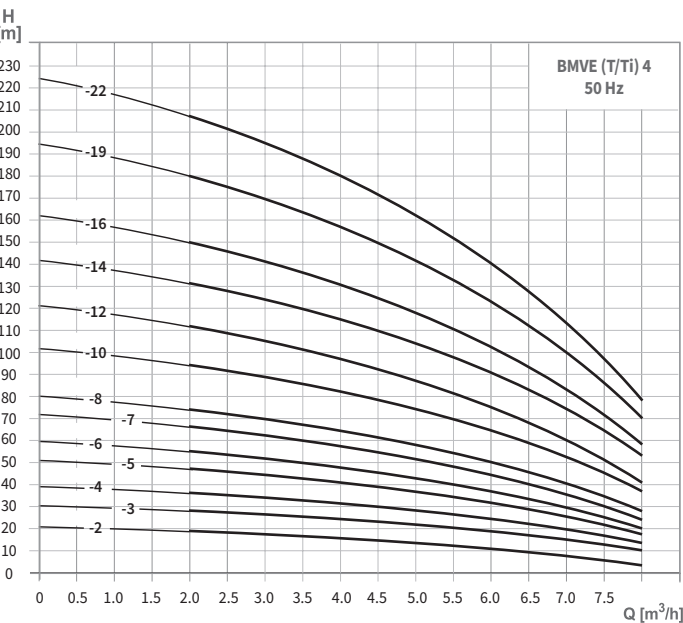
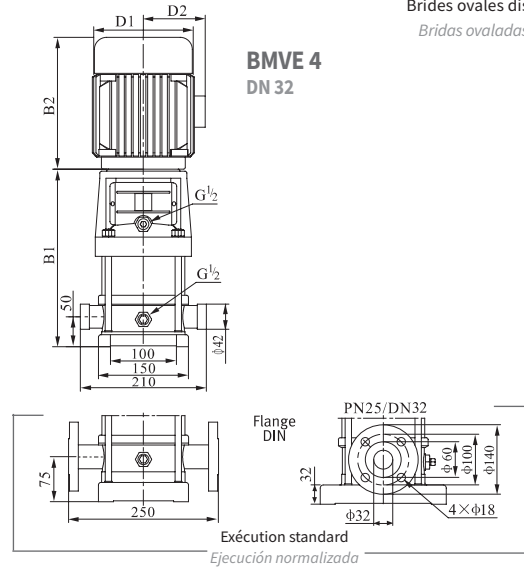

MODÈLE MODELO	PUISSANCE POTENCIA (kW)	DIMENSIONS DIMENSIONES (mm)					POIDS PESO (KG)
		B1	B2	B1+B2	D1	D2	
BMVE (T/Ti) 4-2	0,37	251	210	461	148	117	21
BMVE (T/Ti) 4-3	0,55	278	210	488	148	117	22
BMVE (T/Ti) 4-4	0,75	315	245	560	170	142	25
BMVE (T/Ti) 4-5	1,1	342	245	587	170	142	27
BMVE (T/Ti) 4-6	1,1	369	245	614	170	142	27
BMVE (T/Ti) 4-7	1,5	406	290	696	190	155	33
BMVE (T/Ti) 4-8	1,5	433	290	723	190	155	33
BMVE (T/Ti) 4-10	2,2	487	290	777	190	155	37
BMVE (T/Ti) 4-12	2,2	541	290	831	190	155	38
BMVE (T/Ti) 4-14	3,0	605	315	920	197	165	46
BMVE (T/Ti) 4-16	3,0	659	315	974	197	165	48
BMVE (T/Ti) 4-19	4,0	740	335	1075	230	188	57
BMVE (T/Ti) 4-22	4,0	821	335	1156	230	188	59

Brides ovales disponibles sur demande
Bridas ovaladas disponibles bajo pedido

BMVE (T/Ti) Pompes multicellulaires | Bombas multietapa verticales

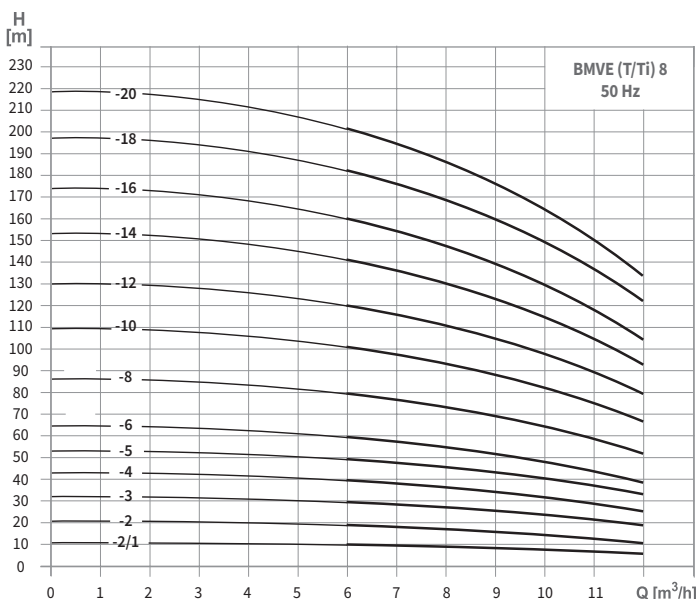

MODÈLE MODELO	PUISSANCE POTENCIA (kW)	DIMENSIONS DIMENSIONES (mm)					POIDS PESO (Kg)
		B1	B2	B1+B2	D1	D2	
BMVE (T/Ti) 8-2/1	0,75	347	245	592	170	142	32
BMVE (T/Ti) 8-2	0,75	347	245	592	170	142	32
BMVE (T/Ti) 8-3	1,1	377	245	622	170	142	34
BMVE (T/Ti) 8-4	1,5	417	290	707	190	155	40
BMVE (T/Ti) 8-5	2,2	447	290	737	190	155	44
BMVE (T/Ti) 8-6	2,2	477	290	767	190	155	45
BMVE (T/Ti) 8-8	3,0	547	315	862	197	165	53
BMVE (T/Ti) 8-10	4,0	607	335	942	230	188	64
BMVE (T/Ti) 8-12	4,0	667	335	1002	230	188	66
BMVE (T/Ti) 8-14	5,5	747	430	1177	260	208	81
BMVE (T/Ti) 8-16	5,5	807	430	1237	260	208	84
BMVE (T/Ti) 8-18	7,5	867	430	1297	260	208	93
BMVE (T/Ti) 8-20	7,5	927	430	1357	260	208	94

Bridas ovales disponibles sur demande
Bridas ovaladas disponibles bajo pedido

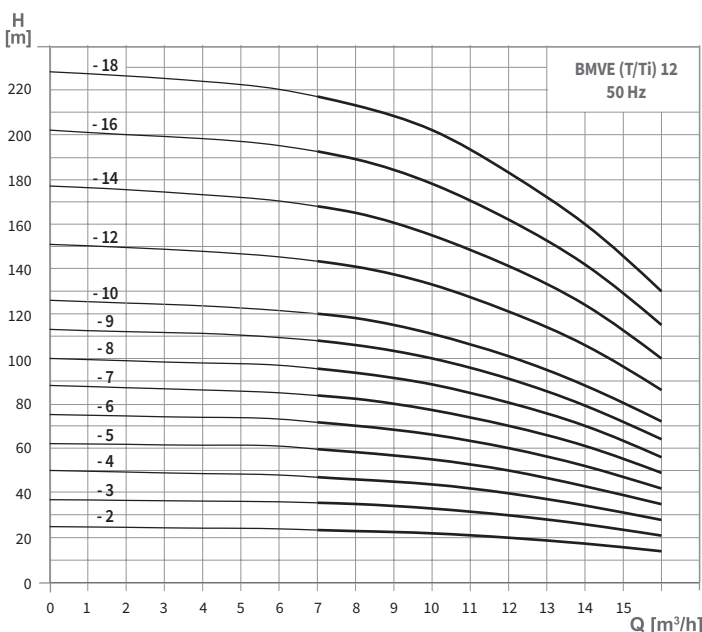
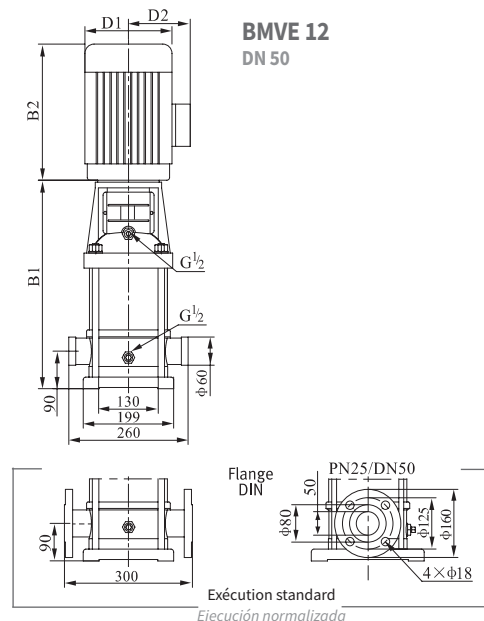
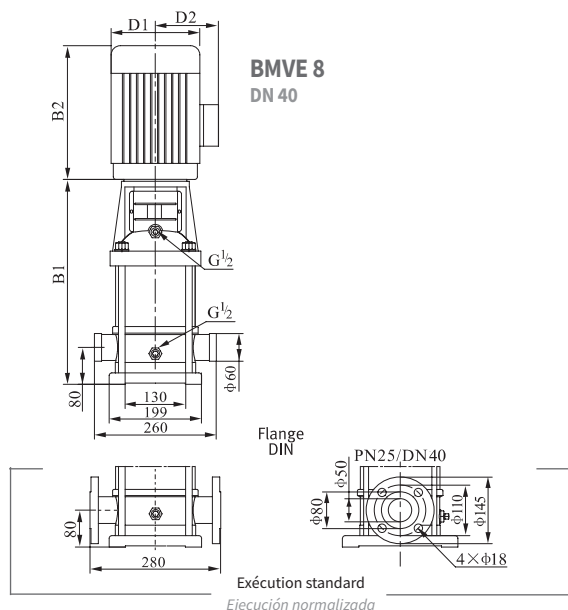

MODÈLE MODELO	PUISSANCE POTENCIA (kW)	DIMENSIONS DIMENSIONES (mm)					POIDS PESO (Kg)
		B1	B2	B1+B2	D1	D2	
BMVE (T/Ti) 12-2	1,5	367	290	657	190	155	39
BMVE (T/Ti) 12-3	2,2	397	290	687	190	155	43
BMVE (T/Ti) 12-4	3,0	437	315	752	197	165	51
BMVE (T/Ti) 12-5	3,0	467	315	782	197	165	53
BMVE (T/Ti) 12-6	4,0	497	335	832	230	188	61
BMVE (T/Ti) 12-7	5,5	547	430	977	260	208	73
BMVE (T/Ti) 12-8	5,5	577	430	1007	260	208	74
BMVE (T/Ti) 12-9	5,5	607	430	1037	260	208	76
BMVE (T/Ti) 12-10	7,5	637	430	1067	260	208	83
BMVE (T/Ti) 12-12	7,5	697	430	1127	260	208	87
BMVE (T/Ti) 12-14	11,0	845	490	1335	330	255	157
BMVE (T/Ti) 12-16	11,0	905	490	1395	330	255	161
BMVE (T/Ti) 12-18	11,0	965	490	1455	330	255	164

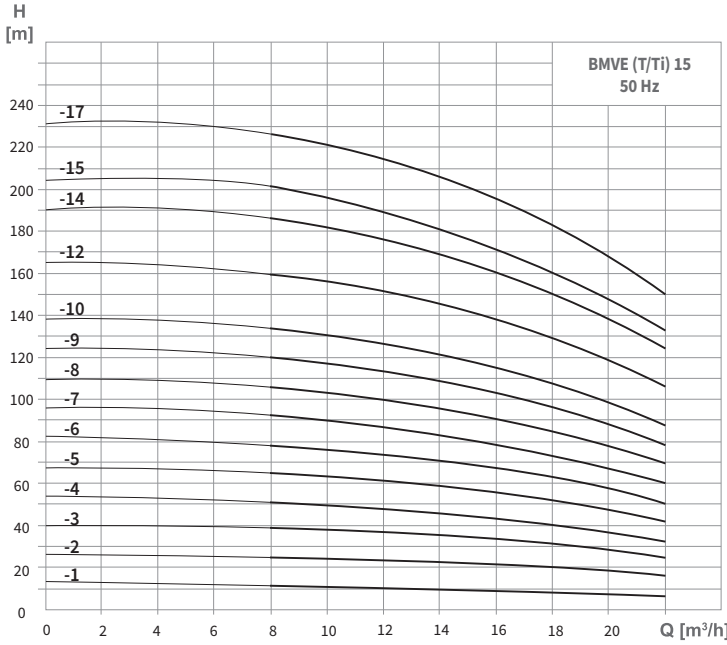

MODÈLE MODELO	PUISSANCE POTENCIA (kW)	DIMENSIONS DIMENSIONES (mm)					POIDS PESO (Kg)
		B1	B2	B1+B2	D1	D2	
BMVE (T/Ti) 15-1	1,1	387	245	632	170	142	33
BMVE (T/Ti) 15-2	2,2	397	290	687	190	155	42
BMVE (T/Ti) 15-3	3,0	452	345	797	197	165	51
BMVE (T/Ti) 15-4	4,0	497	355	852	230	188	60
BMVE (T/Ti) 15-5	4,0	542	355	897	230	188	62
BMVE (T/Ti) 15-6	5,5	607	390	997	260	208	78
BMVE (T/Ti) 15-7	5,5	652	390	1042	260	208	80
BMVE (T/Ti) 15-8	7,5	697	390	1087	260	208	86
BMVE (T/Ti) 15-9	7,5	742	390	1132	260	208	88
BMVE (T/Ti) 15-10	11,0	875	500	1375	330	255	157
BMVE (T/Ti) 15-12	11,0	965	500	1465	330	255	161
BMVE (T/Ti) 15-14	11,0	1055	500	1555	330	255	165
BMVE (T/Ti) 15-15	15,0	1100	500	1600	330	255	167
BMVE (T/Ti) 15-17	15,0	1190	500	1690	330	255	178

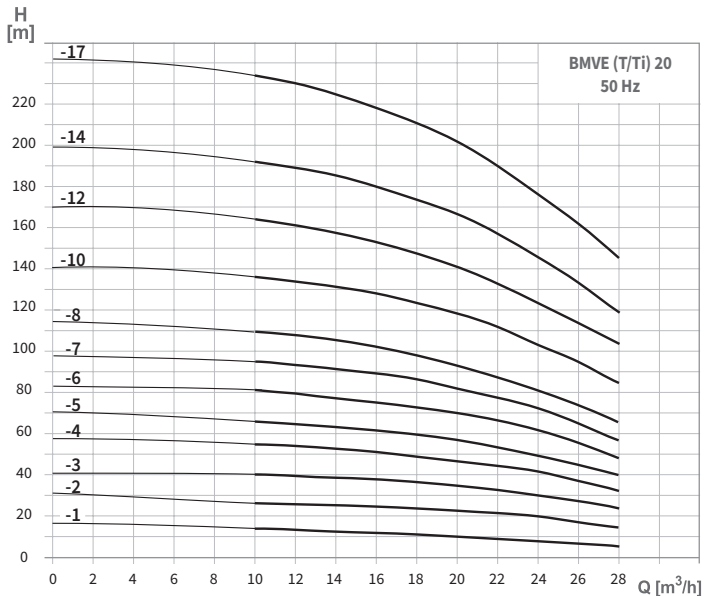
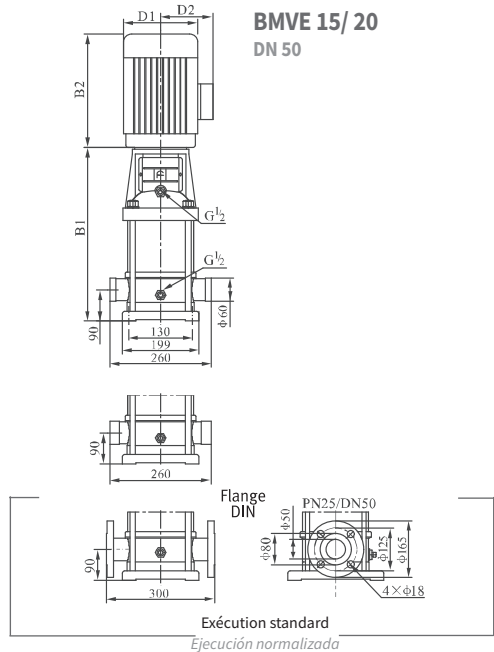

MODÈLE MODELO	PUISSANCE POTENCIA (kW)	DIMENSIONS DIMENSIONES (mm)					POIDS PESO (Kg)
		B1	B2	B1+B2	D1	D2	
BMVE (T/Ti) 20-1	1,1	387	245	632	170	142	33
BMVE (T/Ti) 20-2	2,2	397	290	687	190	155	42
BMVE (T/Ti) 20-3	4,0	452	335	787	230	188	58
BMVE (T/Ti) 20-4	5,5	517	430	947	260	208	74
BMVE (T/Ti) 20-5	5,5	562	430	992	260	208	76
BMVE (T/Ti) 20-6	7,5	607	430	1037	260	208	82
BMVE (T/Ti) 20-7	7,5	652	430	1082	260	208	84
BMVE (T/Ti) 20-8	11,0	785	490	1275	330	255	153
BMVE (T/Ti) 20-10	11,0	875	490	1365	330	255	157
BMVE (T/Ti) 20-12	15,0	965	490	1455	330	255	170
BMVE (T/Ti) 20-14	15,0	1055	490	1545	330	255	172
BMVE (T/Ti) 20-17	18,5	1190	550	1740	330	255	195

BMVE (T/Ti) Pompes multicellulaires | Bombas multietapa verticales

PRESSURISATION / PRESURIZACIÓN

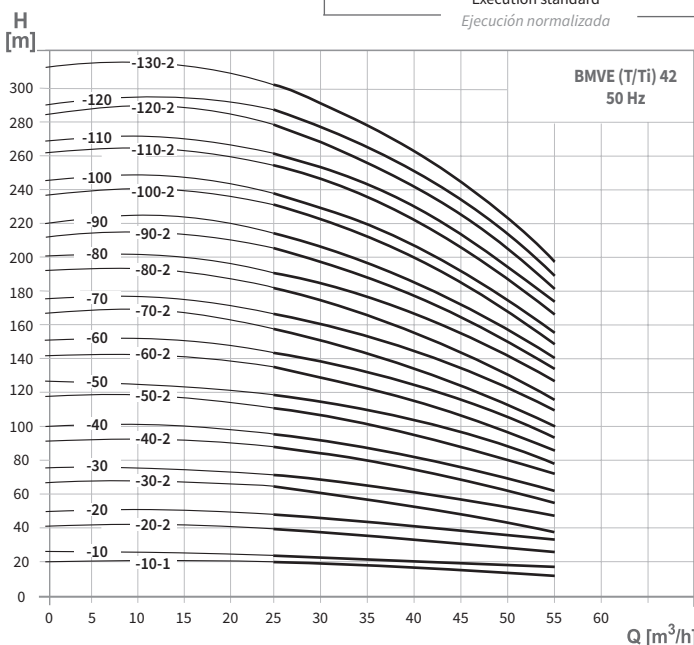
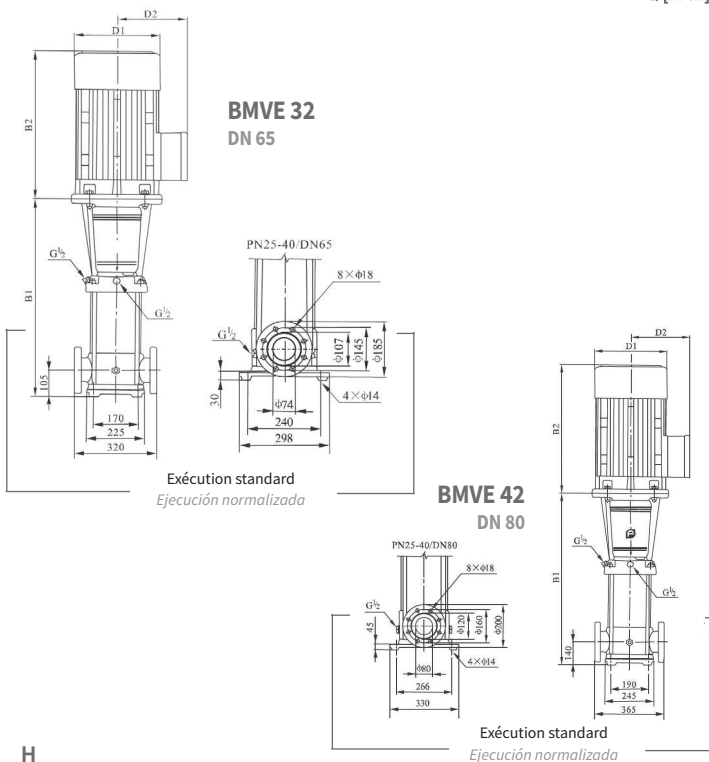
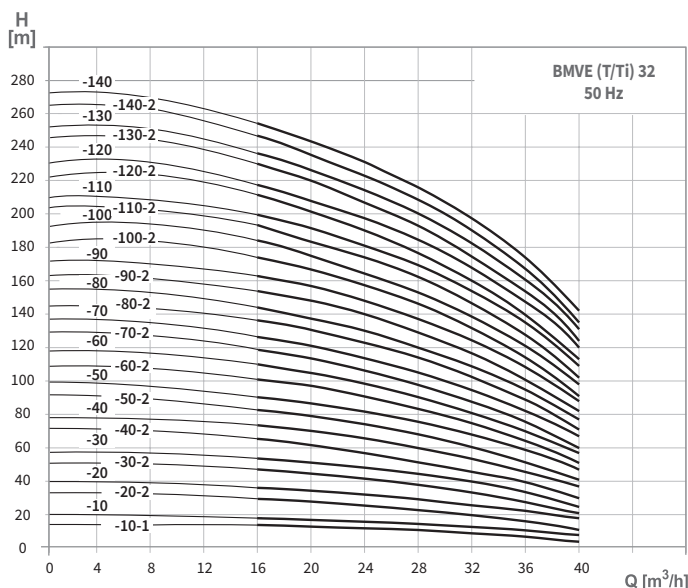

MODÈLE MODELO	PUISSANCE POTENCIA (kW)	DIMENSIONS DIMENSIONES (mm)					POIDS PESO (Kg)
		B1	B2	B1+B2	D1	D2	
BMVE (T/Ti) 32-10-1	1,5	505	290	795	190	155	64
BMVE (T/Ti) 32-10	2,2	505	290	795	190	155	68
BMVE (T/Ti) 32-20-2	3,0	575	315	890	197	165	77
BMVE (T/Ti) 32-20	4,0	575	335	910	230	180	85
BMVE (T/Ti) 32-30-2	5,5	645	430	1075	260	208	100
BMVE (T/Ti) 32-30	5,5	645	430	1075	260	208	100
BMVE (T/Ti) 32-40-2	7,5	715	430	1145	260	208	109
BMVE (T/Ti) 32-40	7,5	715	430	1145	260	208	109
BMVE (T/Ti) 32-50-2	11,0	890	490	1380	330	255	181
BMVE (T/Ti) 32-50	11,0	890	490	1380	330	255	181
BMVE (T/Ti) 32-60-2	11,0	960	490	1450	330	255	185
BMVE (T/Ti) 32-60	11,0	960	490	1450	330	255	185
BMVE (T/Ti) 32-70-2	15,0	1030	490	1520	330	255	199
BMVE (T/Ti) 32-70	15,0	1030	490	1520	330	255	199
BMVE (T/Ti) 32-80-2	15,0	1100	490	1590	330	255	203
BMVE (T/Ti) 32-80	15,0	1100	490	1590	330	255	203
BMVE (T/Ti) 32-90-2	18,5	1170	550	1720	330	255	222
BMVE (T/Ti) 32-90	18,5	1170	550	1720	330	255	222
BMVE (T/Ti) 32-100-2	18,5	1240	550	1790	330	255	227
BMVE (T/Ti) 32-100	18,5	1240	550	1790	330	255	227
BMVE (T/Ti) 32-110-2	22,0	1310	590	1900	360	285	272
BMVE (T/Ti) 32-110	22,0	1310	590	1900	360	285	272
BMVE (T/Ti) 32-120-2	22,0	1380	590	1970	360	285	276
BMVE (T/Ti) 32-120	22,0	1380	590	1970	360	285	276
BMVE (T/Ti) 32-130-2	30,0	1450	660	2110	400	310	337
BMVE (T/Ti) 32-130	30,0	1450	660	2110	400	310	337
BMVE (T/Ti) 32-140-2	30,0	1520	660	2180	400	310	341
BMVE (T/Ti) 32-140	30,0	1520	660	2180	400	310	341

MODÈLE MODELO	PUISSANCE POTENCIA (kW)	DIMENSIONS DIMENSIONES (mm)					POIDS PESO (Kg)
		B1	B2	B1+B2	D1	D2	
BMVE (T/Ti) 42-10-1	3,0	561	315	876	197	165	83
BMVE (T/Ti) 42-10	4,0	561	335	896	230	188	90
BMVE (T/Ti) 42-20-2	5,5	641	430	1071	260	208	105
BMVE (T/Ti) 42-20	7,5	641	430	1071	260	208	110
BMVE (T/Ti) 42-30-2	11,0	826	490	1316	330	255	183
BMVE (T/Ti) 42-30	11,0	826	490	1316	330	255	183
BMVE (T/Ti) 42-40-2	15,0	906	490	1396	330	255	197
BMVE (T/Ti) 42-40	15,0	906	490	1396	330	255	197
BMVE (T/Ti) 42-50-2	18,5	986	550	1536	330	255	221
BMVE (T/Ti) 42-50	18,5	986	550	1536	330	255	221
BMVE (T/Ti) 42-60-2	22,0	1066	590	1656	360	285	261
BMVE (T/Ti) 42-60	22,0	1066	590	1656	360	285	261
BMVE (T/Ti) 42-70-2	30,0	1146	660	1806	400	310	320
BMVE (T/Ti) 42-70	30,0	1146	660	1806	400	310	320
BMVE (T/Ti) 42-80-2	30,0	1226	660	1886	400	310	324
BMVE (T/Ti) 42-80	30,0	1226	660	1886	400	310	324
BMVE (T/Ti) 42-90-2	30,0	1306	660	1966	400	310	328
BMVE (T/Ti) 42-90	37,0	1306	660	1966	400	310	352
BMVE (T/Ti) 42-100-2	37,0	1386	660	2046	400	310	355
BMVE (T/Ti) 42-100	37,0	1386	660	2046	400	310	355
BMVE (T/Ti) 42-110-2	45,0	1466	700	2166	450	345	426
BMVE (T/Ti) 42-110	45,0	1466	700	2166	450	345	426
BMVE (T/Ti) 42-120-2	45,0	1546	700	2246	450	345	432
BMVE (T/Ti) 42-120	45,0	1546	700	2246	450	345	432
BMVE (T/Ti) 42-130-2	45,0	1626	700	2326	450	345	438

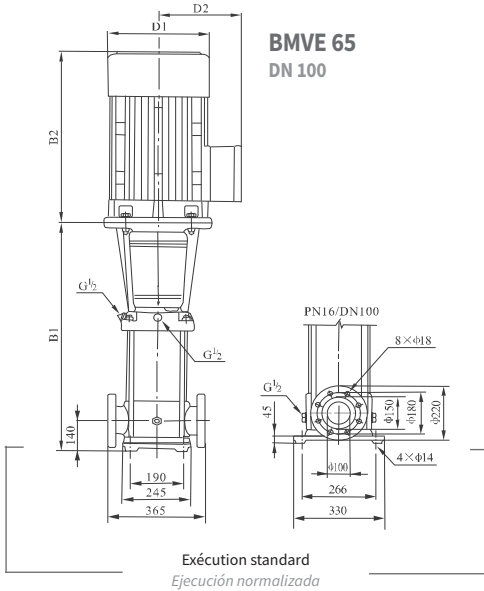
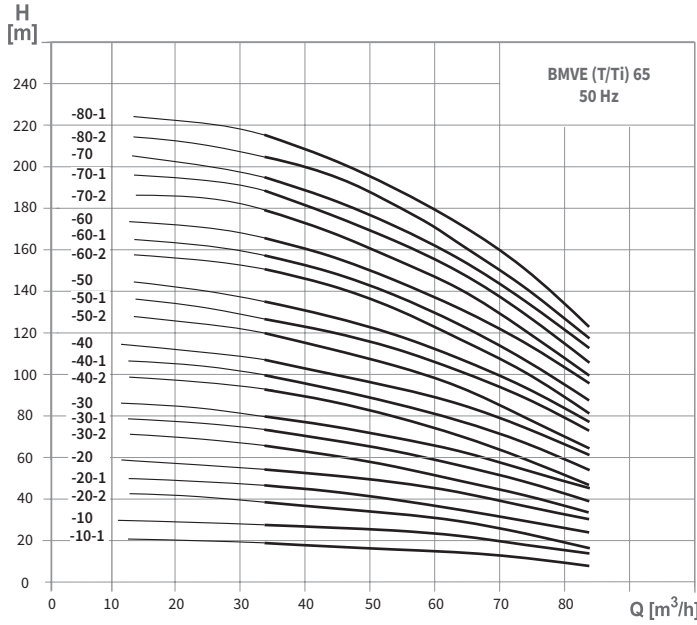

MODÈLE MODELO	PUISSANCE POTENCIA (kW)	DIMENSIONS DIMENSIONES (mm)					POIDS PESO (Kg)
		B1	B2	B1+B2	D1	D2	
BMVE (T/Ti) 65-10-1	4,0	561	335	896	230	188	93
BMVE (T/Ti) 65-10	5,5	561	430	991	260	208	105
BMVE (T/Ti) 65-20-2	7,5	644	430	1074	260	208	110
BMVE (T/Ti) 65-20-1	11,0	754	490	1244	330	255	182
BMVE (T/Ti) 65-20	11,0	754	490	1244	330	255	182
BMVE (T/Ti) 65-30-2	15,0	836	490	1326	330	255	196
BMVE (T/Ti) 65-30-1	15,0	836	490	1326	330	255	197
BMVE (T/Ti) 65-30	18,5	836	550	1386	330	255	221
BMVE (T/Ti) 65-40-2	18,5	919	550	1469	330	255	225
BMVE (T/Ti) 65-40-1	22,0	919	590	1509	360	285	258
BMVE (T/Ti) 65-40	22,0	919	590	1509	360	285	258
BMVE (T/Ti) 65-50-2	30,0	1001	660	1661	400	310	319
BMVE (T/Ti) 65-50-1	30,0	1001	660	1661	400	310	319
BMVE (T/Ti) 65-50	30,0	1001	660	1661	400	310	320
BMVE (T/Ti) 65-60-2	30,0	1084	660	1744	400	310	325
BMVE (T/Ti) 65-60-1 *	37,0	1084	660	1744	400	310	349
BMVE (T/Ti) 65-60 *	37,0	1084	660	1744	400	310	349
BMVE (T/Ti) 65-70-2 *	37,0	1166	660	1826	400	310	353
BMVE (T/Ti) 65-70-1 *	37,0	1166	660	1826	400	310	353
BMVE (T/Ti) 65-70 *	45,0	1166	700	1866	460	340	420
BMVE (T/Ti) 65-80-2 *	45,0	1248	700	1948	460	340	424
BMVE (T/Ti) 65-80-1 *	45,0	1248	700	1948	460	340	424

*PN 25-40/ DN 100 | *PN 25-40/ DN 100

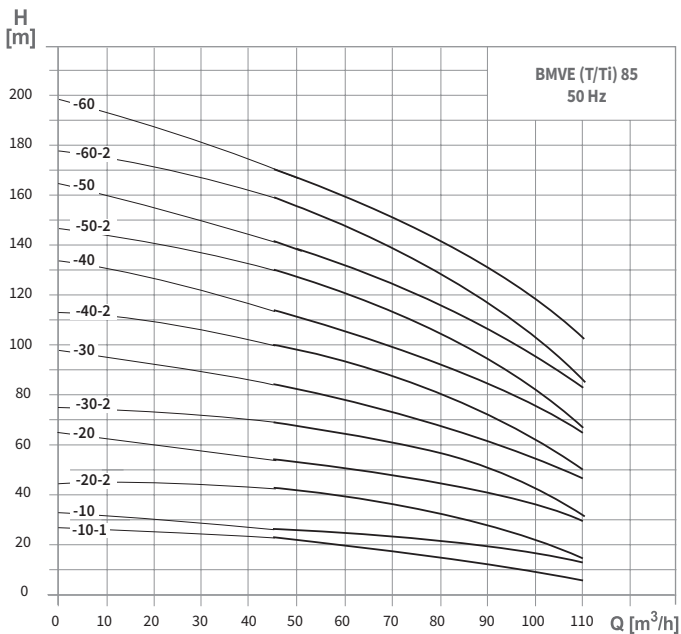
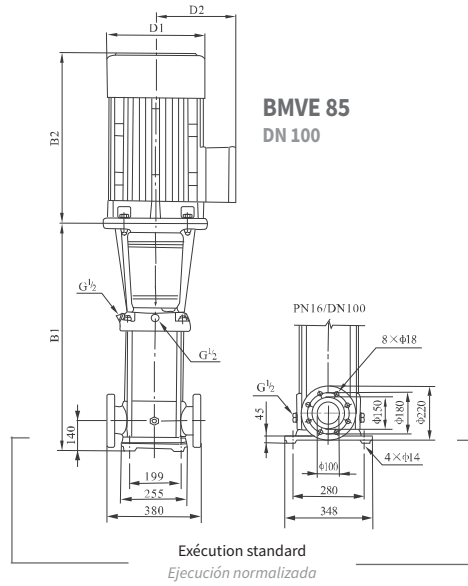

MODÈLE MODELO	PUISSANCE POTENCIA (kW)	DIMENSIONS DIMENSIONES (mm)					POIDS PESO (Kg)
		B1	B2	B1+B2	D1	D2	
BMVE (T/Ti) 85-10-1	5,5	571	430	1001	260	208	105
BMVE (T/Ti) 85-10	7,5	571	430	1001	260	208	110
BMVE (T/Ti) 85-20-2	11,0	773	490	1263	330	255	181
BMVE (T/Ti) 85-20	15,0	773	490	1263	330	255	192
BMVE (T/Ti) 85-30-2	18,5	865	550	1415	330	255	215
BMVE (T/Ti) 85-30	22,0	865	590	1455	360	285	252
BMVE (T/Ti) 85-40-2	30,0	957	660	1617	400	310	312
BMVE (T/Ti) 85-40	30,0	957	660	1617	400	310	312
BMVE (T/Ti) 85-50-2 *	37,0	1049	660	1709	400	310	336
BMVE (T/Ti) 85-50 *	37,0	1049	660	1709	400	310	336
BMVE (T/Ti) 85-60-2 *	45,0	1141	700	1841	460	340	407
BMVE (T/Ti) 85-60 *	45,0	1141	700	1841	460	340	407

*PN 25-40/ DN 100 | *PN 25-40/ DN 100

BMVE (T/Ti) Pompes multicellulaires | Bombas multietapa verticales

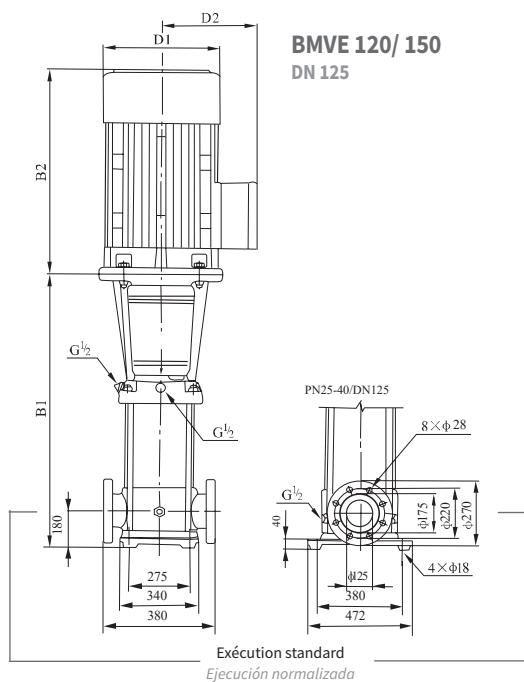
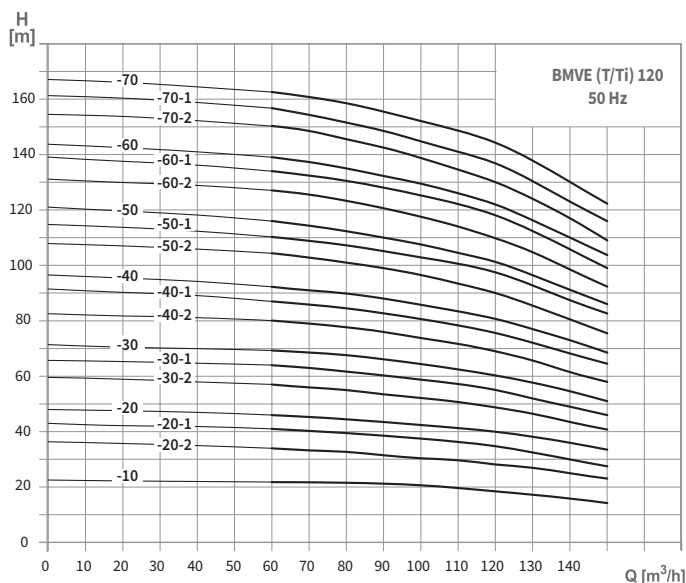

MODÈLE MODELO	PUISSANCE POTENCIA (kW)	DIMENSIONS DIMENSIONES (mm)					POIDS PESO (Kg)
		B1	B2	B1+B2	D1	D2	
BMVE (T/Ti) 120-10	11,0	840	490	1330	330	255	230
BMVE (T/Ti) 120-20-2	15,0	1000	490	1490	330	255	245
BMVE (T/Ti) 120-20-1	18,5	1000	550	1550	330	255	250
BMVE (T/Ti) 120-20	22,0	1000	590	1590	360	285	285
BMVE (T/Ti) 120-30-2	30,0	1160	660	1820	400	310	360
BMVE (T/Ti) 120-30-1	30,0	1160	660	1820	400	310	360
BMVE (T/Ti) 120-30	30,0	1160	660	1820	400	310	360
BMVE (T/Ti) 120-40-2	37,0	1320	660	1980	400	310	400
BMVE (T/Ti) 120-40-1	37,0	1320	660	1980	400	310	400
BMVE (T/Ti) 120-40	45,0	1320	700	2020	460	340	460
BMVE (T/Ti) 120-50-2	45,0	1480	700	2180	460	340	470
BMVE (T/Ti) 120-50-1	45,0	1480	700	2180	460	340	470
BMVE (T/Ti) 120-50	55,0	1510	770	2280	540	370	575
BMVE (T/Ti) 120-60-2	55,0	1670	770	2440	540	370	585
BMVE (T/Ti) 120-60-1	55,0	1670	770	2440	540	370	585
BMVE (T/Ti) 120-60	75,0	1670	845	2515	580	410	705
BMVE (T/Ti) 120-70-2	75,0	1830	845	2675	580	410	715
BMVE (T/Ti) 120-70-1	75,0	1830	845	2675	580	410	715
BMVE (T/Ti) 120-70	75,0	1830	845	2675	580	410	715

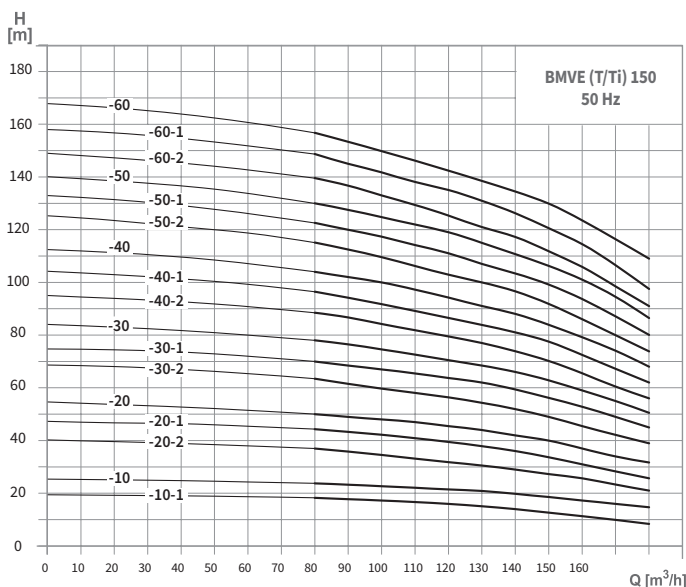

MODÈLE MODELO	PUISSANCE POTENCIA (kW)	DIMENSIONS DIMENSIONES (mm)					POIDS PESO (Kg)
		B1	B2	B1+B2	D1	D2	
BMVE (T/Ti) 150-10-1	11,0	840	490	1330	330	255	230
BMVE (T/Ti) 150-10	15,0	840	490	1330	330	255	235
BMVE (T/Ti) 150-20-2	18,5	1000	550	1550	330	255	250
BMVE (T/Ti) 150-20-1	22,0	1000	590	1590	360	285	295
BMVE (T/Ti) 150-20	30,0	1000	660	1660	400	310	350
BMVE (T/Ti) 150-30-2	30,0	1160	660	1820	400	310	360
BMVE (T/Ti) 150-30-1	37,0	1160	660	1820	400	310	360
BMVE (T/Ti) 150-30	37,0	1160	660	1820	400	310	385
BMVE (T/Ti) 150-40-2	45,0	1320	700	2020	460	340	460
BMVE (T/Ti) 150-40-1	45,0	1320	700	2020	460	340	460
BMVE (T/Ti) 150-40	55,0	1350	770	2120	540	370	560
BMVE (T/Ti) 150-50-2	55,0	1510	770	2280	540	370	570
BMVE (T/Ti) 150-50-1	75,0	1510	845	2355	580	410	690
BMVE (T/Ti) 150-50	75,0	1510	845	2355	580	410	690
BMVE (T/Ti) 150-60-2	75,0	1670	845	2515	580	410	700
BMVE (T/Ti) 150-60-1	75,0	1670	845	2515	580	410	700
BMVE (T/Ti) 150-60	75,0	1670	845	2515	580	410	700

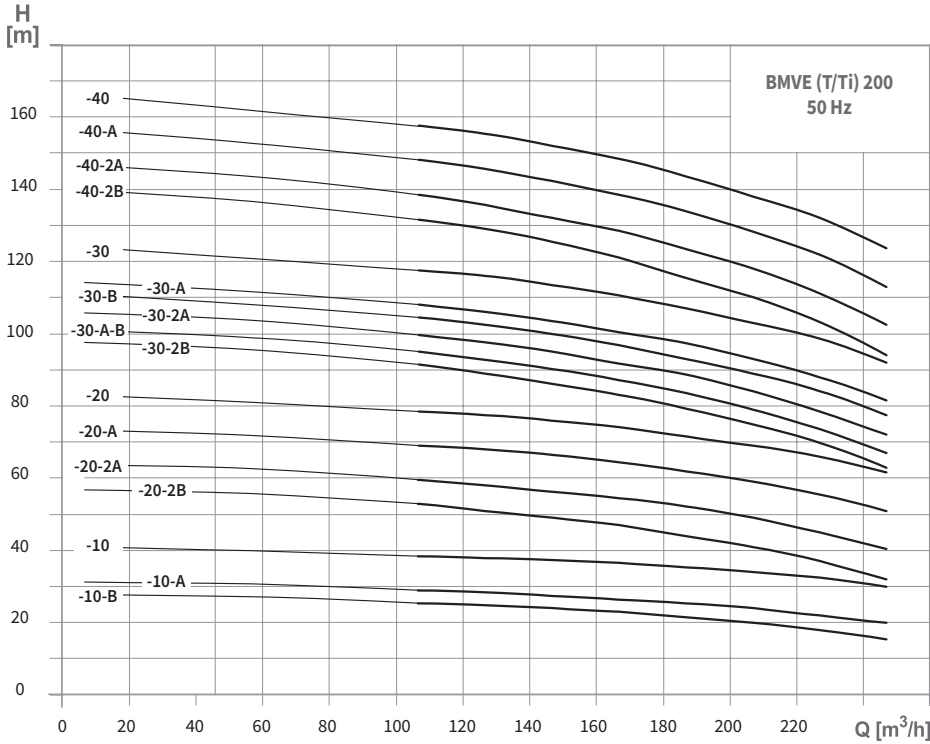

MODÈLE MODELO	PUISSANCE POTENCIA (kW)	DIMENSIONS DIMENSIONES (mm)					POIDS PESO (Kg)
		B1	B2	B1+B2	D1	D2	
BMVE (T/Ti) 200-10-B	18,5	907	550	1457	330	255	311
BMVE (T/Ti) 200-10-A	22,0	907	590	1497	360	285	347
BMVE (T/Ti) 200-10	30,0	907	660	1567	400	310	403
BMVE (T/Ti) 200-20-2B	37,0	1101	660	1761	400	310	447
BMVE (T/Ti) 200-20-2A	45,0	1101	700	1801	460	340	504
BMVE (T/Ti) 200-20-A	55,0	1131	770	1901	540	370	595
BMVE (T/Ti) 200-20	55,0	1131	770	1901	540	370	595
BMVE (T/Ti) 200-30-2B	75,0	1325	845	2170	580	410	748
BMVE (T/Ti) 200-30-A-B	75,0	1325	845	2170	580	410	748
BMVE (T/Ti) 200-30-2A	75,0	1325	845	2170	580	410	748
BMVE (T/Ti) 200-30-B	75,0	1325	845	2170	580	410	748
BMVE (T/Ti) 200-30-A	75,0	1325	845	2170	580	410	748
BMVE (T/Ti) 200-30	90,0	1325	895	2220	580	410	817
BMVE (T/Ti) 200-40-2B	90,0	1519	895	2414	580	410	830
BMVE (T/Ti) 200-40-2A	110,0	1519	1140	2659	645	550	1180
BMVE (T/Ti) 200-40-A	110,0	1519	1140	2659	645	550	1180
BMVE (T/Ti) 200-40	110,0	1519	1140	2659	645	550	1180

