

▶ APLICAÇÕES

Bombagem de efluentes industriais
Trasfega de água e efluentes de tanques
Bombagem de efluentes em ETAR's
Bombagem de efluentes domésticos
Drenagem de águas pluviais
Drenagem de água de inundações

▶ MATERIAIS DE CONSTRUÇÃO

Corpo da bomba: Ferro Fundido GG25
Impulsor: Ferro Fundido GG25
Veio: AISI 420
Empanque superior: Mecânico em Car/ Cer/ NBR ou lip seal em NBR
Empanque inferior: Mecânico em SiC/ SiC/ NBR
O'rings: NBR

▶ LIMITES DE UTILIZAÇÃO

Temperatura máxima do líquido: 40°C
Passagem máxima de sólidos: até 100 mm
Proteções e comando: As versões monofásicas incorporam proteção térmica contra sobrecorrente e interruptor de nível

▶ CARACTERÍSTICAS DO MOTOR

Tensão: 1x230V ou 3x400V
Classe de isolamento: F
Classe de proteção: IP68
Rotação: 1450 e 2900 rpm

▶ APPLICATIONS

Pumping industrial sewage
Transfer of water and sewage from tanks
Pumping sewage in small wastewater stations
Pumping domestic sewage
Drainage of rainwater
Drainage of floodwater

▶ CONSTRUCTION MATERIALS

Pump casing: GG25 Cast Iron
Impeller: GG25 Cast Iron
Shaft: AISI 420
Upper Seal: Mechanical in Car/ Cer/ NBR or Lip seal in NBR
Lower Seal: Mechanical in SiC/ SiC/ NBR
O'rings: NBR

▶ WORKING LIMITS

Maximum liquid temperature: 40°C
Maximum passage of solids: up to 100mm
Protection and control: The single phase versions include thermal overcurrent protection and level switch

▶ MOTOR SPECIFICATIONS

Voltage: 1x230V or 3x400V
Insulation class: F
Protection class: IP68
Rotation: 1450 and 2900 rpm

VTQ



A gama de bombas submersíveis **VTQ**, com impulsor Vortex, são de fabrico robusto e compacto, em ferro fundido, aptas a bombear efluentes com sólidos em suspensão até 100 mm. Podem ser instaladas nas execuções móveis ou fixas com pé de acoplamento. São fornecidas com cabo elétrico de 10 metros, exceto os modelos 1005 que são fornecidos com cabo eléctrico de 5 metros.

The **VTQ** submersible pump series with Vortex impeller are robust and compact, in cast iron, suitable for pumping sewage containing solids up to 100mm. They can be installed on movable or fixed structures with a coupling system. Supplied with a 10 meter electric cable, except the 1005 models which have a 5 meter electric cable.

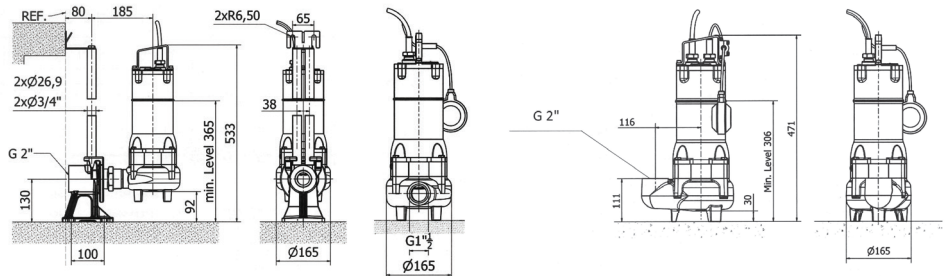
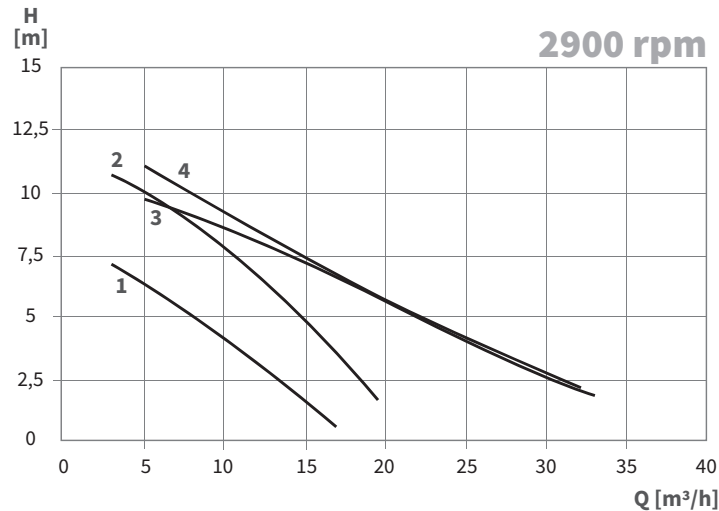

Nº NR.	MODELO MODEL				POTÊNCIA NOMINAL RATED POWER (kW)	CORRENTE MAX. MAX. CURRENT (A)		DND	Ø MAX. SÓLIDOS MAX. SOLIDS Ø (mm)	PESO WEIGHT (Kg)
	SAÍDA HORIZONTAL / HORIZONTAL OUTLET		SAÍDA VERTICAL / VERTICAL OUTLET			1~	3~			
	1~	3~	1~	3~						
1	VTQFF142M-1005	VTQFF142T-1005	VTQFF142M(B)V-1005*	VTQFF142TV-1005	0,45	3,5	1,2	40	35	15,0
2	VTQFF162M-1306	VTQFF162T-1306	VTQFF162M(B)V-1306*	VTQFF162T(B)V-1306*	0,65	4,5	1,6	40	40	23,0
3	VTQFF192M-1507	VTQFF192T-1507	VTQFF192M(B)V-1507*	VTQFF192T(B)V-1507*	1,1	7,5	2,8	40	40	24,0
4	VTQFF112M-1510	VTQFF112T-1510	-	-	1,1	7,7	2,8	40	40	24,5

* B - Modelo disponível com bóia
* B - Model with float available

Bombas para instalação com pé de acoplamento rápido
Pumps for installation with fast coupling feet

VTQ Bombas submersíveis para drenagem e efluentes | Submersible sewage and drainage pumps

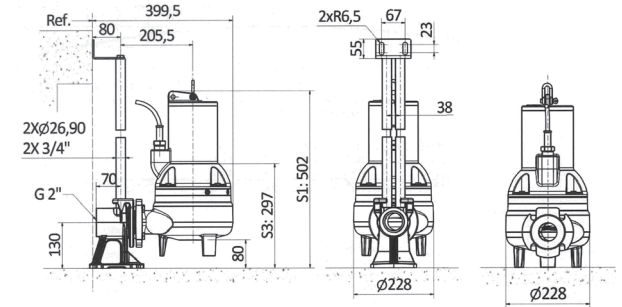
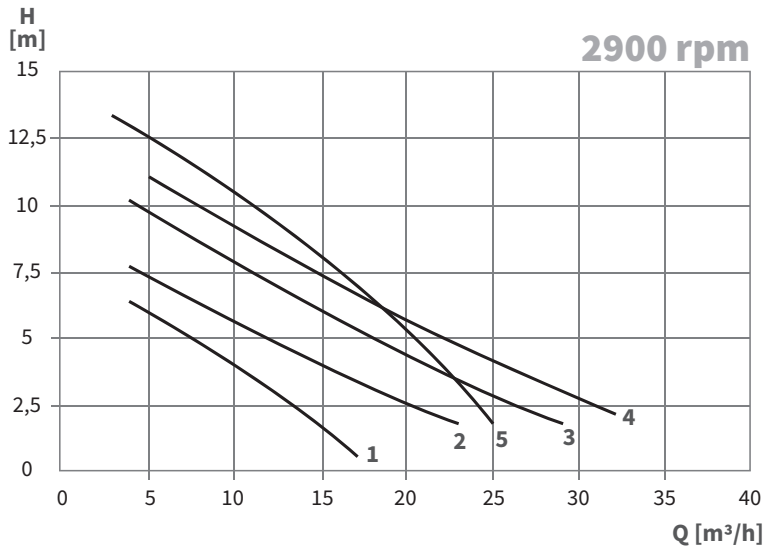

Nº NR.	MODELO MODEL		POTÊNCIA NOMINAL RATED POWER (kW)	ROTAÇÃO ROTATION (rpm)	CORRENTE MAX. MAX. CURRENT (A)		DND	Ø MAX. SÓLIDOS MAX. SOLIDS Ø (mm)	PESO WEIGHT (Kg)
	SAÍDA HORIZONTAL HORIZONTAL OUTLET				SAÍDA VERTICAL VERTICAL OUTLET				
	1 ~	3 ~			1 ~	3 ~			
1	VTQFF242M-1005	VTQFF242T-1005	0,45	2900	3,5	1,2	50	40	15,0
2	VTQFF262M-1306	VTQFF262T-1306	0,6	2900	4,5	1,6	50	50	23,5
3	VTQFF292M-1507	VTQFF292T-1507	1,1	2900	6,7	2,2	50	50	24,5
4	-	-	1,1	2900	7,7	2,8	50	40	24,5
5	VTQFF212M-1510	VTQFF212T-1510	1,1	2900	7,7	2,8	50	50	24,5

Bombas para instalação móvel/fixa
Pumps for movable/ fixed structure

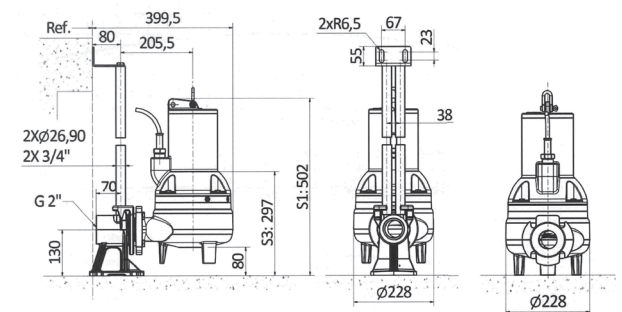
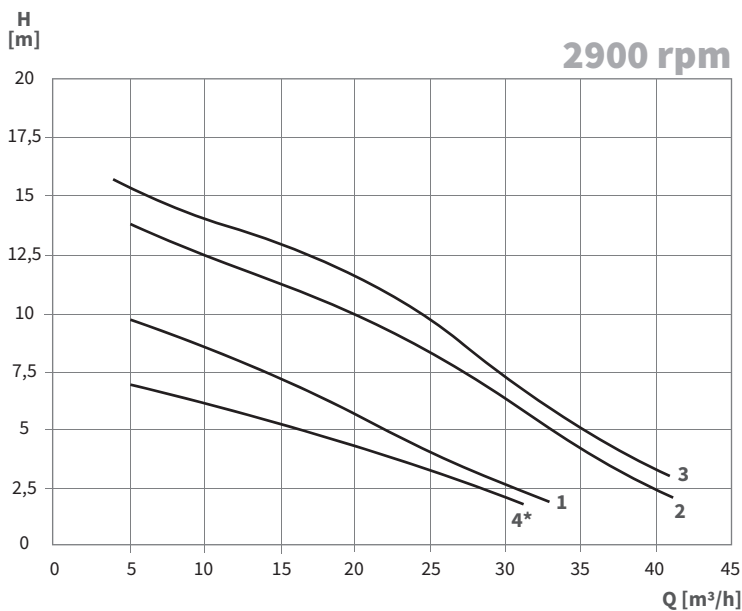

4* bomba a 4 polos / 4-pole pump

Nº NR.	MODELO MODEL		POTÊNCIA NOMINAL RATED POWER (kW)	ROTAÇÃO ROTATION (rpm)	CORRENTE MAX. MAX. CURRENT (A)		DND	Ø MAX. SÓLIDOS MAX. SOLIDS Ø (mm)	PESO WEIGHT (Kg)
	SAÍDA HORIZONTAL HORIZONTAL OUTLET				SAÍDA VERTICAL VERTICAL OUTLET				
	1 ~	3 ~			1 ~	3 ~			
1	VTQFF112M-1507	VTQFF112T-1507	1,1	2900	7,9	2,7	50	48	35,0
2	-	VTQFF182T-2308	1,8	2900	-	4,8	50	48	35,7
3	-	VTQFF222T-2509	2,4	2900	-	5,5	50	48	36,0
4	-	VTQFF114T-1904	1,2	1450	-	3,8	50	48	37,7

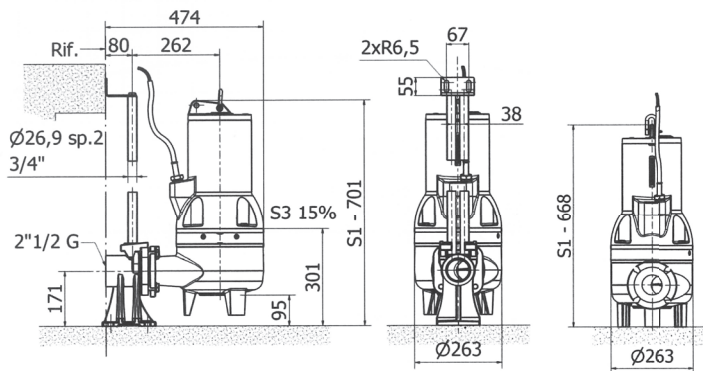
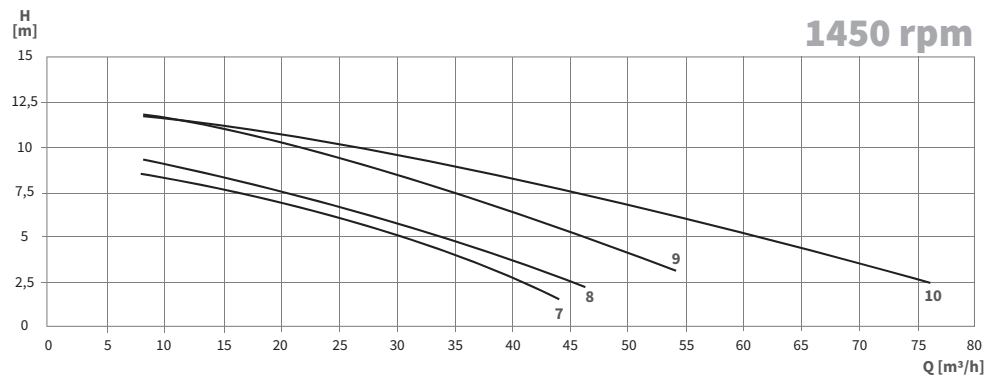
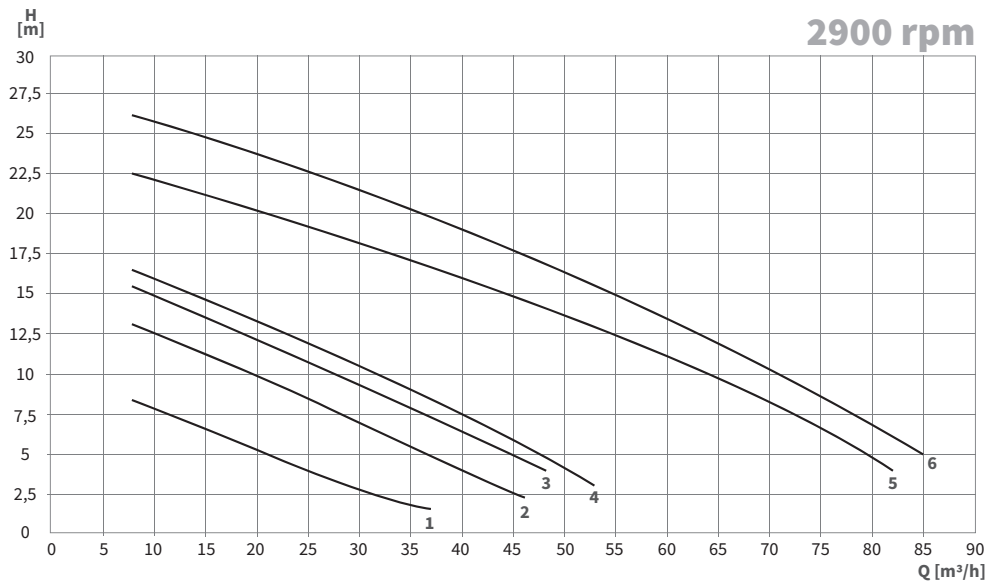

Nº NR.	MODELO MODEL		POTÊNCIA NOMINAL RATED POWER (kW)	ROTAÇÃO ROTATION (rpm)	CORRENTE MAX. MAX. CURRENT (A)		DND	Ø MAX. SÓLIDOS MAX. SOLIDS Ø (mm)	PESO WEIGHT (Kg)
	1~	3~			1~	3~			
	1	VTQFF112M-2006			VTQFF112T-2006	1,1			
2	-	VTQFF182T-2807	2,2	2900	-	5,5	65	65	57
3	-	VTQFF222T-3109	2,4	2900	-	5,5	65	65	58
4	-	VTQFF302T-3309	3	2900	-	6,5	65	65	62
5	-	VTQFF372T-4315	4,4	2900	-	10	65	60	80
6	-	VTQFF552T-4021	7,5	2900	-	12,5	65	60	85
7	-	VTQFF114T-2505	1,1	1450	-	3,2	65	65	58
8	-	VTQFF184T-2606	1,8	1450	-	4,4	65	65	62
9	-	VTQFF224T-3208	2,2	1450	-	5,5	65	65	66
10	-	VTQFF304T-5006	4	1450	-	7	65	53	83

Bombas para instalação com pé de acoplamento rápido
Pumps for installation with fast coupling feet

VTQ Bombas submersíveis para drenagem e efluentes | Submersible sewage and drainage pumps

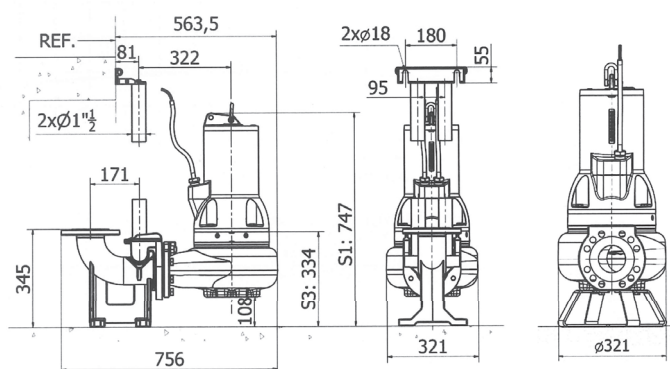
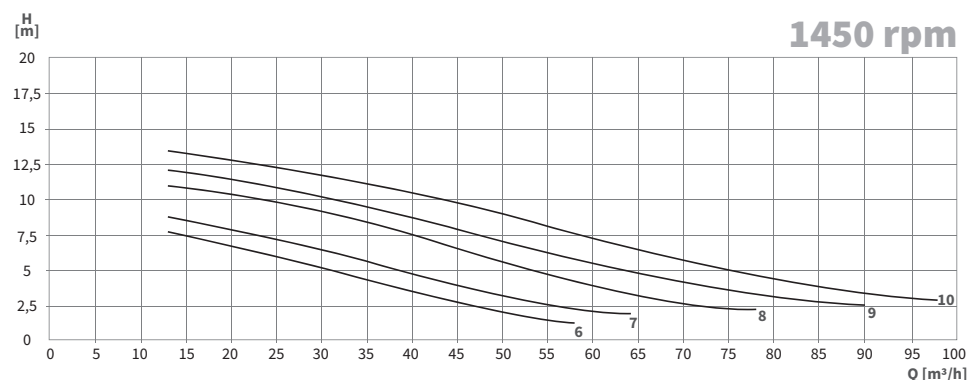
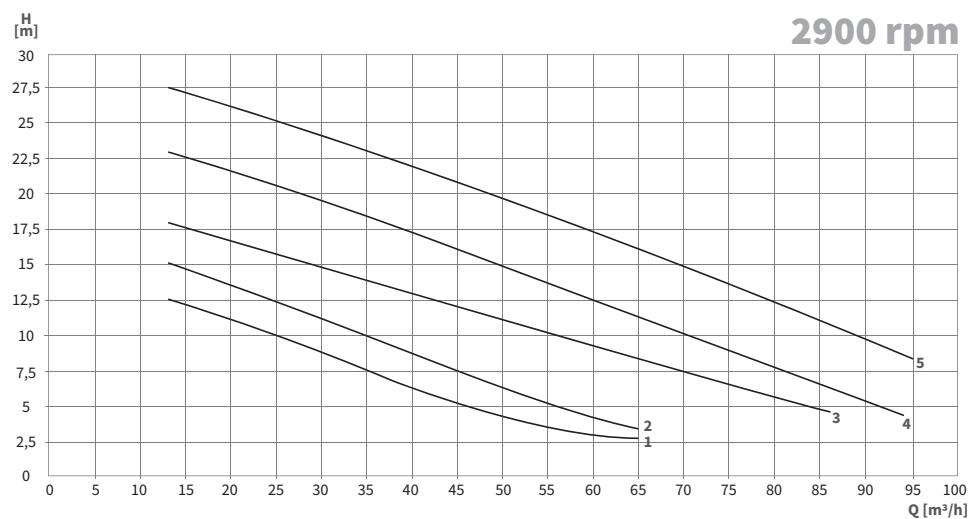

Nº NR.	MODELO MODEL	POTÊNCIA NOMINAL	ROTAÇÃO	CORRENTE MAX.	DND	Ø MAX. SÓLIDOS MAX. SOLIDS Ø	PESO WEIGHT
		RATED POWER (kW)	ROTATION (rpm)	MAX. CURRENT (A)			
1	VTQFF222T-3208	2,2	2900	5,4	80	80	71
2	VTQFF302T-3809	3,0	2900	6,8	80	80	75
3	VTQFF372T-4013	4,4	2900	10	80	80	103
4	VTQFF552T-4018	5,5	2900	12,4	80	80	108
5	VTQFF752T-4023	7,5	2900	16,8	80	80	110
6	VTQFF114T-3204	1,1	1450	3	80	80	70
7	VTQFF154T-3805	1,8	1450	4,8	80	80	74
8	VTQFF224T-3808	2,2	1450	5,5	80	80	76
9	VTQFF304T-5007	3,0	1450	7	80	80	107
10	VTQFF404T-6009	4,0	1450	8,1	80	80	108

Bombas para instalação com pé de acoplamento rápido
Pumps for installation with fast coupling feet

EFLUENTES E DRENAGEM | SEWAGE AND DRAINAGE

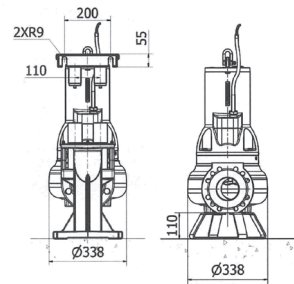
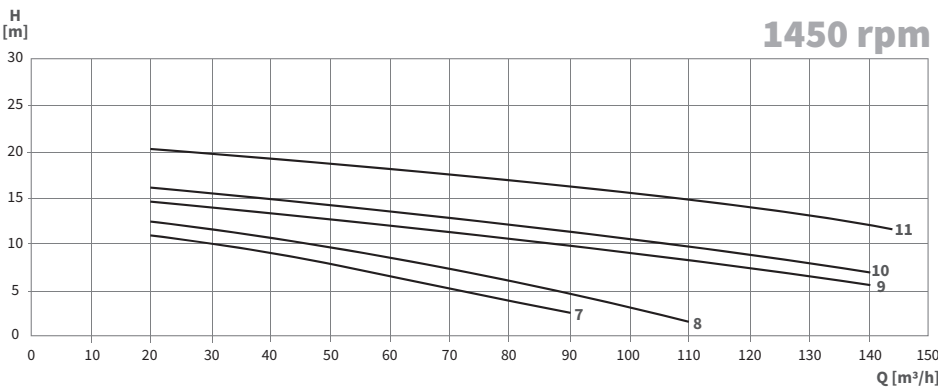
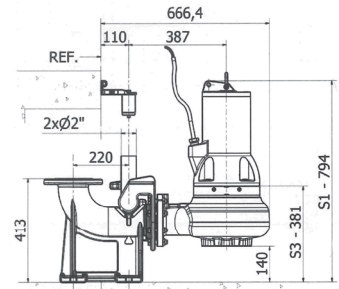
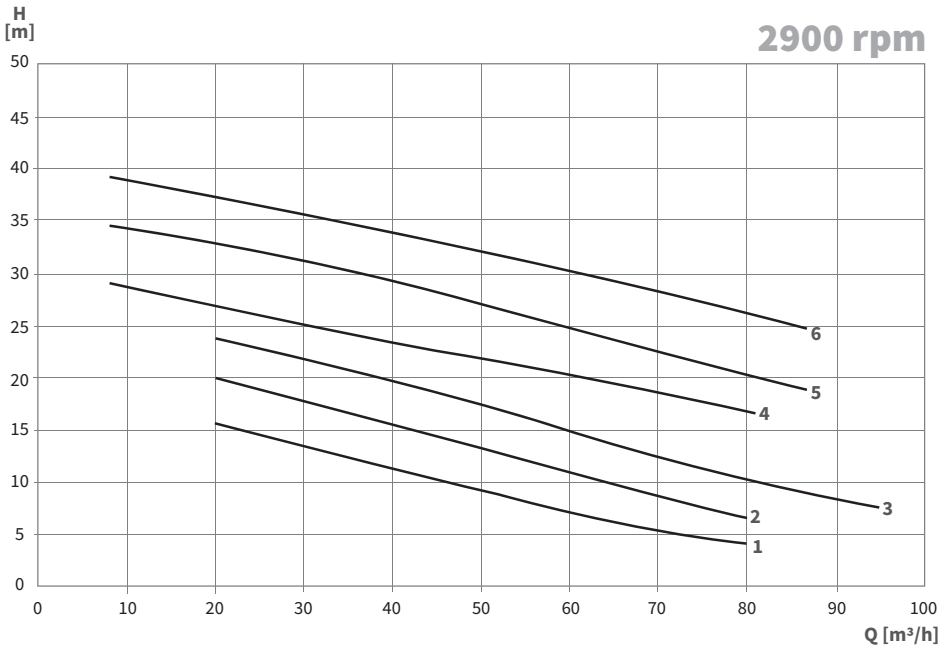

Nº NR.	MODELO MODEL	POTÊNCIA NOMINAL RATED POWER (kW)	ROTAÇÃO ROTATION (rpm)	CORRENTE MAX. MAX. CURRENT (A)	DND	Ø MAX. SÓLIDOS MAX. SOLIDS Ø (mm)	PESO WEIGHT (Kg)
1	VTQFF372T-4014	4,4	2900	10,0	100	90	105
2	VTQFF552T-4015	5,5	2900	12,4	100	90	108
3	VTQFF752T-4019	7,5	2900	16,8	100	90	112
4	VTQFF1102T-7019*	11,0	2900	23,0	100	100	160
5	VTQFF1302T-7022*	13,0	2900	29,0	100	100	196
6	VTQFF1502T-7228*	15,0	2900	32,0	100	100	200
7	VTQFF304T-5008	3,0	1450	7,0	100	92	108
8	VTQFF404T-6008	4,0	1450	8,2	100	90	110
9	VTQFF554T-9510*	5,5	1450	13,6	100	100	220
10	VTQFF754T-10011*	7,5	1450	15,3	100	100	220
11	VTQFF904T-11515*	9,0	1450	1,7	100	100	220

Bombas para instalação com pé de acoplamento rápido
Pumps for installation with fast coupling feet

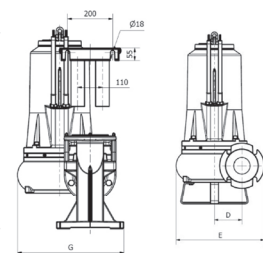
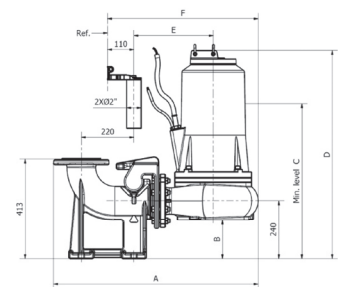

* Atravancamento para as bombas assinaladas.
* Drawing to the indicated pumps